

CONDOMINIUM "T"  
DOCUMENTS

OFF. REC. 16030M0513

93R419125 1993 AUG 24 12:21

AMENDMENT TO DECLARATION OF COSTA DEL SOL CONDOMINIUM "I"

WHEREAS, the Declaration of Condominium of Costa del Sol Condominium "I" was duly recorded in the Official Records Book of Dade County, as follows:

Costa del Sol Condominium "I" - O.R. 14302, p 443.

WHEREAS, the original developer intended to create a multiphase project the common areas of which would be subject to the control of one association, as evidenced by the Declarations of Condominium for Costa del Sol Condominium No. 1, duly recorded in the Official Records Book of Dade County 8716, page 450; Costa del Sol Condominium No. 2, duly recorded in the Official Records Book of Dade County 8716, Page 528; Costa del Sol Condominium No. 3, duly recorded in the official Records Book of Dade County 8716, Page 607, Costa del sol Condominium No. 4, Page 684, and by the Declaration of Restrictions and Maintenance Covenants for "Costa del Sol", duly recorded in the official Records Book of Dade County Official Record 14302, Page 443; and

WHEREAS, the Declaration of Costa del Sol Condominium "I" recognizes that the original developer had expressed its commitment to the creation of an open-ended association whose membership would be comprised of all the owners of all the condominiums then existing or to be constructed within the Costa del Sol project; and

WHEREAS, the Declaration of Costa del Sol Condominium "I" recognizes that a final determination made by a court of competent jurisdiction, with respect to the obligations of Association No. 1 to own and maintain the common areas, would be conclusive as to the powers of Association No. 1 to own and maintain all of the common areas within the Costa del Sol project; and

WHEREAS, by Final Judgment rendered on April 29, 1981, in the case of Jay Core, et al. v. ERO Properties, Inc., et al., Eleventh Circuit Case No. 80-2984, the Court found that:

44

REF: 1603010514  
REC: 1603010514

5. Costa del Sol Association, Inc. ("the Association") is a Florida not-for-profit corporation and is the sole condominium association governing the affairs and maintaining the affairs and maintaining the property of Costa del Sol.

6. The Association not only is the governing authority for the condominiums, but is the condominium association that was intended by the original developer to govern the future condominiums which may be constructed at Costa del Sol.

39. The Association has the right and duty to control, regulate and manage all of the condominiums which are to be constructed at Costa del Sol.

44. The Plaintiffs ...have proved by a preponderance of the evidence that material allegations of Counts I and II of the Complaint. Accordingly, they shall have Final Judgment ...and the following relief:

46. At such time as the condominiums are constructed within Costa del Sol, the unit owners therein will become members of the Association and be entitled to vote for the election of directors of the Association's Board in accordance with the provisions of the Condominium Documents.

WHEREAS, all of the units conveyed to individual purchasers by the successor developer, Lennar Homes, Inc., were conveyed subject to the Declaration of Restrictions and Maintenance Covenants for Costa del Sol and Exhibits thereto, and subject to the Declaration of Covenants, Restrictions and Easements for Common Areas and Exhibits thereto; and

WHEREAS, the Costa del Sol Condominium Association "I" is desirous of recording this Amendment so as to provide notice to those individuals who acquire units in the Condominium; and

WHEREAS, the Amendment has been approved by the Costa del Sol Condominium "T" in accordance with the applicable provisions of said Declaration of Condominium;

NOW, THEREFORE, in consideration of the matters contained herein, the undersigned do hereby recite the following:

Section 1.3 Name. The name by which this condominium is to be identified is: Costa del Sol Condominium "I" (hereinafter called "Condominium "I" and/or "the Condominium").

Section 2.2 "Articles" means the Articles of Incorporation of Costa del Sol Condominium Association, Inc.

PT. REC. 16030P0515

- Section 2.4 "Association" means Costa del Sol Condominium Association, Inc., a Florida corporation not for profit, the entity responsible for the operation of Costa del Sol Condominiums Estepona 1, 2, 3 and 4 and Condominium Cluster A and Costa del Sol Condominium A, B, C, D, E, F, G, H, I, J, K, L, M, N, O, P, Q, R, S, T, U, V, W.
- Section 2.5 ~~"Association-Not-2" means the Costa del Sol Property Owners Association-Not-2, Inc., a Florida corporation not for profit, the entity responsible for the operation of the Common Areas.~~
- Section 2.8 "By-laws" means the By-laws of the Costa del Sol Condominium Association, Inc.
- Section 2.12 "Common Expenses" means all expenses incurred and Assessments (and Special Assessments levied against all of the Units of the Condominium) by the Association ~~for the Condominium.~~
- Section 2.13 "Common Surplus" means the excess of all receipts of the Association collected on behalf of the Condominiums, including but not limited to, Assessments, Special Assessments, rents, profits and revenues on account of the Common Elements, and the amount of Common Expenses.
- Section 2.15 "Condominium Property" means the land and personal property that are subject to condominium ownership under the Declaration, all improvements on the land, and all easements and rights appurtenant thereto intended for use in connection with the Condominiums.
- Section 2.17 "Costa del Sol Project Lands" means and refers to the land upon which the Costa del Sol Project is to be located and constructed, which lands are delineated on the Site Plan attached to the Prospectus as Exhibit 1. ~~With the exception of this Condominium and the existing condominiums created by Developer, the Costa del Sol Project -- Stage 2 to be constructed on the Costa del Sol Project Lands is a projected plan of development only and nothing herein contained shall be construed as making it obligatory upon the Developer to construct said project or in accordance with any particular plan of development.~~
- Section 2.19 "Costa del Sol Project - Stage 2", except as provided in Section 2.18 above, means the developed portions of the Costa del Sol Project consisting of Condominiums A, B, C, D, E, F, G, H, I, J, K, L, M, N, O, P, Q, R, S, T, U, V, W and of Costa Del Sol Cluster A Condominium.
- Section 2.23 "Improvements" means all structures and artificial changes to the natural environment (exclusive of landscaping) on the Condominium Property, including but not limited to, ~~the Building or Buildings a Building.~~
- Section 3.4 (a) Support. Each unit of each Building shall have an easement of support and of necessity and shall be subject to an easement of support and necessity in favor of all other Units and the Common Elements.

OFF. REC: 1603070516

- (b) Easements are reserved under, through and over the Condominium Property as may be required from time to time for utility and other services and drainage in order to serve the Condominium. A Unit Owner shall do nothing within or outside his Unit that interferes with or impairs, or may interfere with or impair, the provision of such utility or other services or drainage facilities or the use of these easements. The Board of Directors of the Association or its designee shall inspect same, to maintain, repair or replace the pipes, wires, ducts, vents, cables, conduits and other utility, service and drainage facilities and Common Elements contained in the Unit or elsewhere in the Condominium Property.

Section 7.2 Common Elements. Except to the extent (i) expressly provided to the contrary herein, or (ii) proceeds of insurance are made available therefor, all maintenance, repairs and replacements in or to the Common Elements (~~other than Limited-Common elements-as-provided-above~~) of Condominium "T" shall be performed by Association and the cost and expense thereof shall be charged to all Unit Owners the Owners of Units in Condominium "T" as a Common Expense, except to the extent arising from or necessitated by the negligence, misuse or neglect of specific Unit-Owners Owners of Units in Condominium "T", in which case such cost and expense shall be paid solely by such Unit Owners.

Section 8 Additions, Alterations or Improvements by the Association. Whenever, in the judgment of the Board of Directors, the Common Elements of Condominium "T" or any part thereof shall require capital additions, alterations or improvements (as distinguished from repairs and replacements) costing in excess of \$5,000.00 in the aggregate in any calendar year, the Association may proceed with such additions, alterations or improvements only if the making of such additions, alterations or improvements shall have been approved by a majority of ~~the~~ voting interests of the Units in Condominium "T", represented at a meeting at which a quorum is attained. Any such additions, alterations or improvements to such Common Elements or any part thereof costing in the aggregate of \$5,000.00 or less in a calendar year may be made by the Association without the approval of the Unit-Owners Owners of Units in Condominium "T". The cost and expense of any such additions, alterations or improvements to such Common Elements shall constitute a part of the Common Expenses and shall be assessed to the Unit Owners Owners of Units in Condominium "T" as Common Expenses.

Section 11 Operation of the Condominium by the Association; Power and Duties. ~~The Association shall be the entity responsible for the operation of the condominium.~~ In order to provide for the efficient and effective administration of Condominium "T" by the Unit Owners, and particularly in conjunction with other Condominiums constructed, or which will be constructed in the future within the Costa del Sol Project, a not-for-profit corporation known as Costa del Sol Association, Inc. (heretofore and and hereinafter referred to as "the Association")

OFF. REC. 1603070517

has been organized for the purpose of administering the operation and management of Condominium "T" and all other Condominiums within the Costa del Sol Project. The powers and duties of the Association shall include those set forth in the Articles of Incorporation and By-laws of the Association, ~~(respectively, Exhibits-4-and-5 annexed-here)~~, as amended from time to time. In addition, the Association shall have all the powers and duties set forth in the Act, as well as all powers and duties granted to or imposed upon it by this Declaration, including, without limitation:

- (f) Subsequent to the recording of the Amendments to this Declaration, the Association, when authorized by a majority of the voting interests of the Units represented at a meeting at which a quorum has been attained, shall have the power to acquire and enter into agreements for the acquisition of fee interests, leaseholds, memberships and other possessory or use interests in lands or facilities, including, but not limited to, country clubs, golf courses, marinas and other recreational facilities, whether or not contiguous to the lands of the Unit Owners (whether or not on an exclusive basis). The expenses of ownership (including the expense of making and carrying any mortgage related to such ownership), rental, membership fees, operation, replacements and other expenses and undertakings in connection therewith shall be Common Expenses. No actions authorized hereunder, however, may be taken without prior consent of Developer as long as the Developer owns any Units.

Section 11.01 Membership: The members of the Association shall consist of all the record owners of units in the Condominiums from time to time, and after the termination of the condominiums shall also consist of those who were members at the time of such termination, and their successors and assigns.

Section 12 Determination of the Common Expenses and Fixing of Assessments Therefor. The Board of Directors shall from time to time, and at least annually, prepare a budget for the Condominium "T", determine the amount of Assessments payable by the Unit Owners to meet the Common Expenses of the Condominium "T", and allocate and assess such expenses among the Unit Owners in accordance with the provisions of this Declaration and the By-Laws. The Board of directors shall advise all Unit Owners promptly in writing of the amount of the Assessment payable by each of them as determined by the board of Directors as aforesaid and shall furnish copies of each budget, on which such Assessments are based, to all Unit Owners and (if requested in writing) to their respective mortgagees. The Common Expenses shall include the expenses of the operation, maintenance, repair and replacement of the Common Elements, Special Assessments levied against all of the Units of the Condominium, costs of carrying out the powers and duties of the Association and any other expenses designated as Common Expenses by the Act, this Declaration, the Articles or By-Laws of the Association, applicable rules and regulations, or by the Association. Any budget adopted shall be subject to change to

REF: 1603000518  
REC:

cover actual expenses at any time. Any such change shall be adopted consistent with the provisions of the By-Laws. Additionally, any charges for cable television services and auxiliary services, if provided to all of the Units of the Condominium "T", shall be deemed to be a Common Expense. The Board of Directors in determining the amount of the Assessments payable by the Unit Owners shall be authorized to include such charges in the estimated operating budget for the Condominium "T". Accordingly, the provisions contained in Section 13 of this Declaration with respect to the collection of Assessments shall be applicable to the charges for cable television services and auxiliary services.

Section 12.1 Costa del Sol Project Costs. Each Unit Owner shall be charged with a portion of those costs and expenses (herein referred to as "Costa del Sol Costs") incurred by the Association in connection with those facilities and amenities of the entire Costa del Sol Project, such as, by way of illustration and not in limitation thereof, the maintenance, costs and expense of maintaining and operating the Common Areas, the maintenance of the roadways and easements of ingress and egress, any street lighting facilities, any security services which may from time to time be employed by the Association, any expenditures, capital or otherwise, utilized in connection with the lawns or landscaped areas or irrigation systems, and any other costs and expenses necessary to maintain the Common Areas within the Costa del Sol Project. The portion of the Costa del Sol Costs to be paid by each Unit Owner shall be a fraction, the numerator of which shall be one and the denominator of which shall be the total number of Units in all of the separate Condominiums located within the Costa del Sol Project.

Section 16.2 Determination Whether to Continue Condominium "T". Whether the Condominium "T" will be continued after condemnation will be determined in the manner provided for determining whether damaged property will be reconstructed and repaired after casualty. For this purpose, the taking by eminent domain shall also be deemed to be a casualty.

Section 16.3 Disbursement of Funds. If the Condominium "T" is terminated after condemnation, the proceeds of the awards and Special Assessments will be deemed to be insurance proceeds and shall be owned and distributed in the manner provided with respect to the ownership and distribution of insurance proceeds if the Condominium "T" is terminated after condemnation, the size of the Condominium "T" will be reduced and the property damaged by the taking will be made usable in the manner provided below. The proceeds of the awards and Special Assessments shall be used in the manner provided for disbursements of funds by the Insurance Trustee (if appointed) after a casualty, or as elsewhere in this Section 16 specifically provided.

Section 16.5 (c) Adjustment of Shares. The shares in the Common Elements, Common Expenses and Common Surplus appurtenant to the Units that continue as part of the Condominium "T" shall be adjusted to distribute the shares in the

REC. 1603070519

Common Elements, Common Expenses and Common Surplus among the reduced number of Unit Owners (and among reduced Units). This shall be effected by restating the shares of continuing Unit Owners as follows:

Section 18.2 ~~Consent of Unit Owners to Purchase or lease of Units by the Association.~~  
Consent of Board of Directors. The Association shall not exercise any option hereinabove set forth to purchase or lease any Unit without the prior approval of Owners of a majority of the voting interests present in person or by proxy and of a majority of the members of the Board of Directors voting at a meeting at which a quorum has been obtained.

Section 24 Background Information. The original developer of the Costa del Sol Project was the Costa del Sol Golf & Racquet Club, Inc., a Florida corporation, (the "Original Developer"). The Costa del Sol Project was established under the terms and provisions of the Act by the Original Developer as a "Phase Development".

The Original Developer created four condominiums consisting of 201 residential condominium units and known as Costa del Sol Condominium No. 1 (66 Units), Costa del Sol Condominium No. 2 (36 Units) Costa del Sol Condominium No. 3 (53 Units) and Costa del Sol Condominium No. 4 (46 Units). The Original Developer caused to be formed the Costa del Sol Association, Inc., a corporation not for profit (the "Original Association"). The Original Association is responsible for maintenance, operation, administration and upkeep of each of the condominiums as well as the Common Areas. The structure of the Original Association is "open-ended" and contemplates the admission of additional unit owners as members if, as and when, additional Condominiums are established at the Costa del Sol Project, (i.e., the Unit Owners in this Condominium).

The Original Developer caused to be prepared and placed of record on July 2, 1974, in Official Records Book 8718 at Page 847 of the Public Records of Dade County, Florida, an instrument entitled Declaration of Restrictions and Maintenance Covenants for "Costa del Sol" and Exhibits thereto (the "Original Declaration"), which instrument provides for, among other things, the rights, benefits, duties, obligations and burdens imposed upon the owners of property in the Costa del Sol project (for example, the future owners of condominium units including the condominium units in this Condominium) with respect to the Common Areas.

The covenants, restrictions, easements, conditions, liens and assessments set forth in the Original Declaration and all amendments thereto, are covenants running with the title to the respective Units and are binding upon the Owners thereof, their heirs, successors and assigns, as provided in said instruments. However, this Declaration shall not have the effect of reimposing the covenants, restrictions, easements, conditions, liens and assessments contained in the



OFF. REC. 16030P0520

Original Declaration and all amendments thereto upon the Units of the Owners thereof.

- (b) The Common Areas -- Rights and Obligations of Unit Owners and Association No. 1 (Original Association) -- The Original Developer and the members of the Original Association have an unrestricted and perpetual easement of ingress and egress to, over, under, above and upon the common Areas, as common Areas are defined in the Original Declaration. These easements and the easement of enjoyment to the Common Areas in favor of every present and future owner of any "lot" in the Costa del Sol Project are subject to the right of either the Original Developer or Original Association to do certain acts and things in respect of the aforesaid Common Areas, as provided for in the Original Declaration.

Additionally, the original Declaration imposes certain obligations on owners of condominium units in the existing condominiums in Costa del Sol Project -- State 1, on the Unit Owners in this Condominium and future Unit owners.

Pursuant to the provision of that certain Declaration of Covenants, Restrictions and Easements for common Areas recorded on May 5, 1981 under Clerk's File No. 81R11058 (and as may be amended by recorded Supplemental Declarations) in the Public Records of Dade County, Florida every Unit Owner shall have a non-exclusive perpetual easement of ingress and egress to, over, under, above and upon the Common Areas, as Common Areas are defined in the Common Areas Declaration, which easement shall be appurtenant to and shall pass with title to every Unit. The covenants, restrictions, easements, conditions, equitable servitudes, liens and assessments set forth in said Common Areas Declaration (including recorded Supplemental Declarations) shall be covenants running with the title to the respective Units and shall be binding upon the Owners thereof, their heirs, successors and assigns, as provided in said instrument. Until a court makes a final determination in respect of the obligation of Association No. 1 to maintain and own the Common Areas, the Developer (as a future owner of the Common Areas) would be reluctant to convey or cause the Successor Developer to convey title to the Common Areas to Association No. 1.

Section 27.1 Notices. All notices to the Association required or desired hereunder or under the By-Laws of the Association shall be sent by certified mail (return receipt requested) to the Association care of its office, located at at the Condominium, One Costa Del Sol Boulevard, Miami, Florida 33178, or to such other address as the Association may hereafter designate from time to time by notice in writing to all Unit Owners. Except as provided specifically in the Act, all notices to any Unit Owner shall be sent by first class mail to the

REF: 16030P0521

Condominium address of such Unit Owner, or such other address as may have been designated by him from time to time, in writing, to the Association. All notices to mortgagees of Units shall be sent by first class mail to their respective addresses, or such other address as may be designated by them from time to time, in writing, to the Association. All notices shall be deemed to have been given when mailed in a postage-prepaid, sealed wrapper, except notice of a change of address, which shall be deemed to have been given when received, or five (5) business days after proper mailing, whichever shall first occur.

IN WITNESS WHEREOF, the undersigned have executed this Amendment to the Declaration the day and year first above written.

Signed, sealed and delivered in the presence of

COSTA DEL SOL Condominium T

President

Secretary

STATE OF FLORIDA  
COUNTY OF DADE

The foregoing instrument was acknowledged before me this 15 day of March, 1991 by Rex Wheeler, President and Secretary, respectively, of Costa del Sol Condominium T, a Florida corporation, on behalf of said corporation.

NOTARY PUBLIC, State of Florida

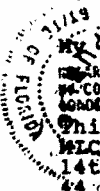

My Commission Expires  
MICHAEL L. HYMAN, ESQ.  
14th Floor Courthouse Tower  
44 West Flagler Street  
Miami, Florida 33130

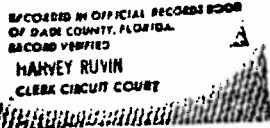

NOV 27 AM 9 51 89R427086

OFF. REC. 1433891883

THIRD AMENDMENT TO THE DECLARATION OF CONDOMINIUM OF COSTA DEL SOL CONDOMINIUM T

THIS THIRD AMENDMENT to the Declaration is made this 27th day of November, 1989 by Lennar Homes, Inc., a Florida corporation, ("Lennar").

WITNESSETH:

WHEREAS, the Declaration of Condominium (the "Declaration") of COSTA DEL SOL CONDOMINIUM T (the "Condominium") was recorded on October 24, 1989 under Clerk's File No. 89P386191 in Official Records Book 14302 at Page 443, in the Public Records of Dade County, Florida; and

WHEREAS, Lennar is the present owner of the Condominium Parcels in the Condominium more particularly described in Exhibit "A" attached hereto, and which real property is also described in Exhibit "3" to the Declaration; and

WHEREAS, Lennar has substantially completed Building 113 of the Condominium and the improvements thereto, as shown on Exhibit "A", and desires to amend the Declaration as herein provided.

NOW, THEREFORE, for value and consideration, the receipt of which is hereby acknowledged, Lennar hereby amends the Declaration by submitting, annexing and subjecting the property appearing on Exhibit "A" hereto to Exhibit "3" of the Declaration.

IN WITNESS WHEREOF, the undersigned has executed this Third Amendment to the Declaration the day and year first above written.

Signed, sealed and delivered in the presence of:

LENNAR HOMES, INC.

*Beatrice S. Priddy*

By: *M. E. Saleda*  
M. E. SALEDA, Vice President

*Janet S. English*

Attest: *M. J. Watsky*  
MORRIS J. WATSKY  
Assistant Secretary

STATE OF FLORIDA  
COUNTY OF DADE

The foregoing instrument was acknowledged before me this 27th day of November, 1989 by M. E. SALEDA and MORRIS J. WATSKY, Vice President and Assistant Secretary, respectively, of Lennar Homes, Inc., a Florida corporation, on behalf of said corporation.

*Janet S. English*  
Notary Public, State of Florida

My Commission Expires:  
NOTARY PUBLIC STATE OF FLORIDA  
MY COMMISSION EXP. AUG. 10, 1992  
BONDED THRU GENERAL INS. UND.

This Instrument Prepared By:  
Morris J. Watsky, Esq.  
700 N.W. 107th Avenue  
Miami, FL 33172

46.50





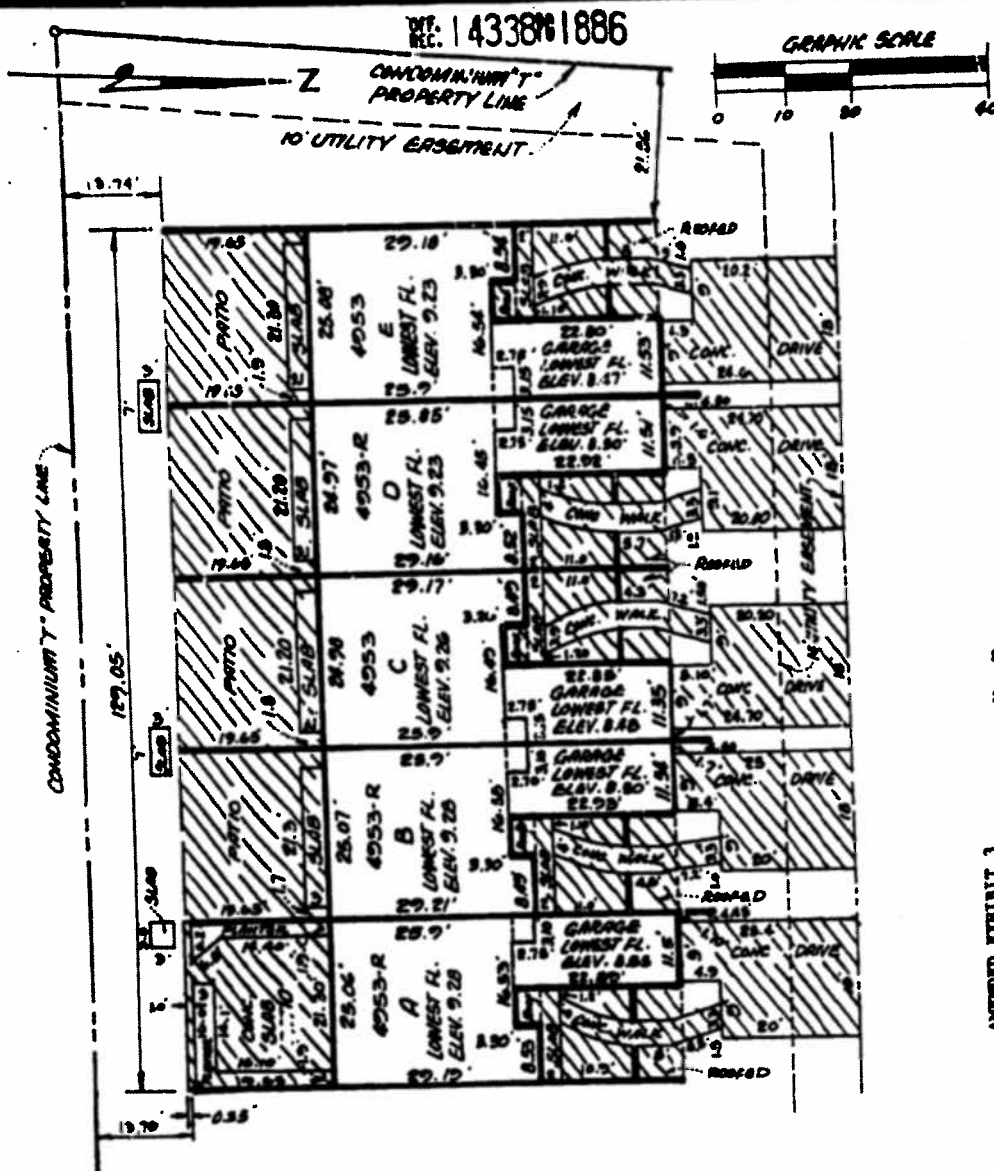

**AMENDED EXHIBIT 3**  
**COSTA DEL SOL CONDOMINIUM "T"**  
**BUILDING NO. 113**  
**FIRST FLOOR PLAN**

DENOTES LIMITED COMMON ELEMENT

**NOTES:**

1. Subject to variations of 0.1'± for each unit.
2. All elevations refer to National Geodetic Vertical Datum of 1929.
3. These plans and elevations are compiled from plans prepared by Bellinson Architect, P.A. and supplemented by actual field surveys.

REF. 1433871887

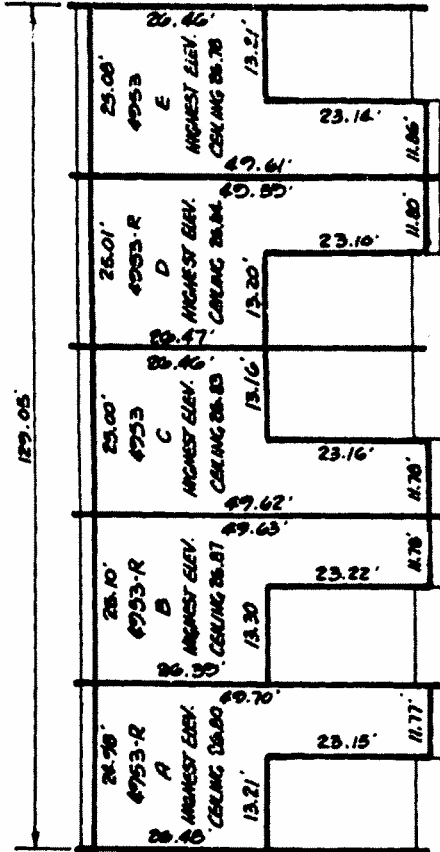
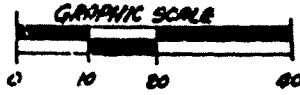
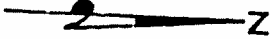

AMENDED EXHIBIT 3  
**COSTA DEL SOL CONDOMINIUM "T"**  
**BUILDING NO. 113**  
**SECOND FLOOR PLAN**

**NOTES:**

1. Subject to variations of 0.1't for each unit.
2. All elevations refer to National Geodetic Vertical Datum of 1929.
3. These plans and elevations are compiled from plans prepared by Beilinson Architect, P.A. and supplemented by actual field surveys.

REF: 1433801888

SURVEYOR'S CERTIFICATE

The undersigned, being a surveyor authorized to practice in the state of Florida, hereby certifies that construction of the improvements within COSTA DEL SOL CONDOMINIUM "T" comprising Building 113 is substantially complete so that the materials comprising this Amended Exhibit 3 to the Declaration of Condominium of COSTA DEL SOL CONDOMINIUM "T" together with the provisions of the Declaration describing the condominium property, is an accurate representation of the location and dimensions of the improvements comprising Building Number 113, and so that the identification, location and the dimensions of the common elements and of each unit within Building Number 113 can be determined from these materials.

The undersigned further certifies that all planned improvements for Building Number 113, including but not limited to, landscaping, utility services and access to the units within Building Number 113 and common element facilities serving Building Number 113, have been substantially completed and meets the minimum technical standards adopted by the Florida Board of Professional Land Surveyors in Chapter 21 WH-6, Florida Administrative Code.

JACK MUELLER & ASSOCIATES, INC.

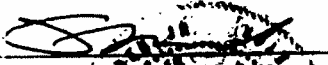
By   
Robin  
Reg. Land Surveyor  
State of Florida  
Date November 11, 1999

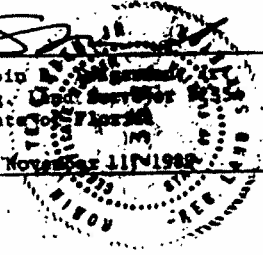

SURVEYOR'S NOTES:

These plans are compiled from plans and data furnished by Lennar Homes, Inc., supplemented by such field survey and measurements as deemed necessary by Jack Mueller & Associates, Inc.

CLERK NOTE:  
FOR CONDOMINIUM PLANS SEE OFFICIAL  
RECORDS CONDOMINIUM PLANS BK229 PAGE 12

RICHARD P. BRINKER, CLERK  
CIRCUIT & COUNTY COURT  
 & C.

RECORDED IN OFFICIAL RECORDS BOOK  
OF DADE COUNTY, FLORIDA  
RECORDS VERIFIED  
RICHARD P. BRINKER  
CLERK CIRCUIT COURT



NOV 20 PM 2:47

53R421997

OFF: 14333PG 315  
REC:

SECOND AMENDMENT TO THE DECLARATION OF CONDOMINIUM

OF COSTA DEL SOL CONDOMINIUM T

THIS SECOND AMENDMENT to the Declaration is made this 20th day of November, 1989 by Lennar Homes, Inc., a Florida corporation, ("Lennar").

WITNESSETH:

WHEREAS, the Declaration of Condominium (the "Declaration") of COSTA DEL SOL CONDOMINIUM T (the "Condominium") was recorded on October 24, 1989 under Clerk's File No. 89R386191 in Official Records Book 14302 at Page 443, in the Public Records of Dade County, Florida; and

WHEREAS, Lennar is the present owner of the Condominium Parcels in the Condominium more particularly described in Exhibit "A" attached hereto, and which real property is also described in Exhibit "3" to the Declaration; and

WHEREAS, Lennar has substantially completed Building 111 of the Condominium and the improvements thereto, as shown on Exhibit "A", and desires to amend the Declaration as herein provided.

NOW, THEREFORE, for value and consideration, the receipt of which is hereby acknowledged, Lennar hereby amends the Declaration by submitting, annexing and subjecting the property appearing on Exhibit "A" hereto to Exhibit "3" of the Declaration.

IN WITNESS WHEREOF, the undersigned has executed this Second Amendment to the Declaration the day and year first above written.

Signed, sealed and delivered in the presence of:

LENNAR HOMES, INC.

*Janet S English*  
*Beatrice S Pelled*

By:   
ALLAN J. PEKOR,

Attest:   
MORRIS J. WATSKY,  
Assistant Secretary

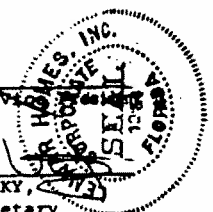

STATE OF FLORIDA  
COUNTY OF DADE

The foregoing instrument was acknowledged before me this 20th day of November, 1989 by ALLAN J. PEKOR and MORRIS J. WATSKY, Vice President and Assistant Secretary, respectively, of Lennar Homes, Inc., a Florida corporation, on behalf of said corporation.

*Janet S English*  
Notary Public, State of Florida

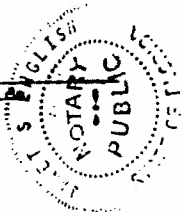

My Commission Expires ~~12/31/92~~ of FLORIDA  
NOTARY PUBLIC STATE OF FLORIDA  
MY COMMISSION EXP. AUG. 10, 1992  
BONDED THRU GENERAL INS. 0000.

This Instrument Prepared By:  
Morris J. Watsky, Esq.  
700 N.W. 107th Avenue  
Miami, FL 33172

46.50

OFF. REC. 14333PG 316

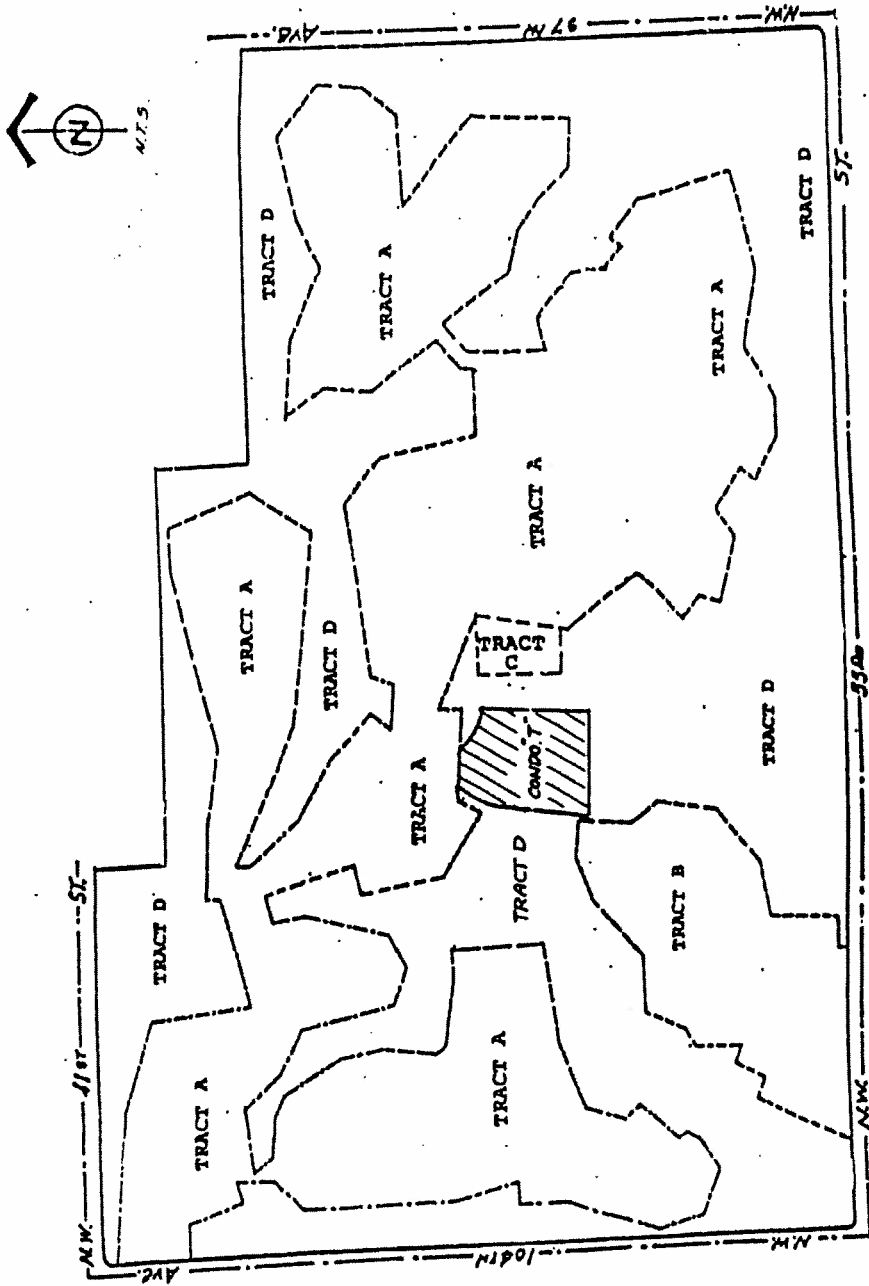

CLERK NOTE:  
FOR DECLARATION OF CONDOMINIUM  
SEE OFFICIAL RECORD BK-1111 PG. 315

*COSTA DEL SOL TRACT "D" AMENDED  
P.B. 137, P. 71*

AMENDED EXHIBIT 3  
COSTA DEL SOL  
CONDOMINIUM "T" LOCATION PLAN

OFF. REC. 14333PG 317

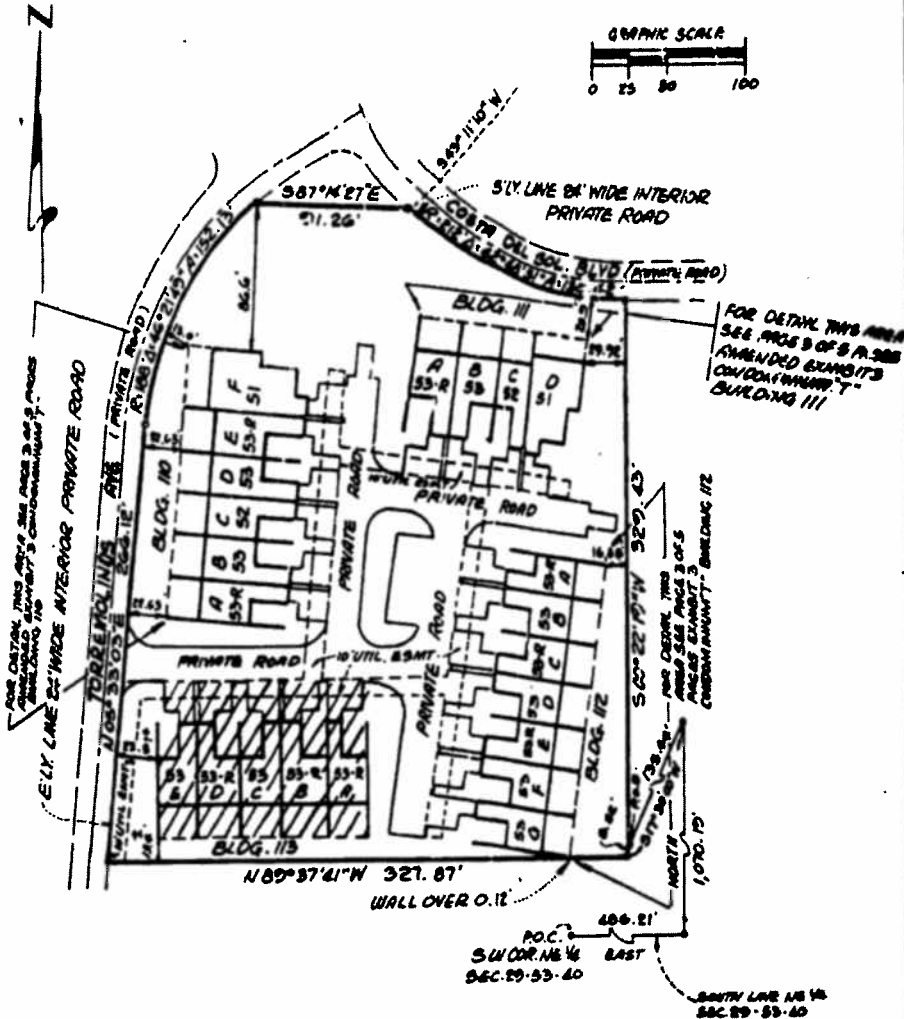

o Denotes set 1" iron pipe with Cap I.B 0064

 Denoted future building

**NOTE:** TORREMOLINOS AVE. and COSTA DEL SOL BLVD. (not a part of CONDOMINIUM "T" property) and the private road within CONDOMINIUM "T" property are easements for ingress and egress for the use and enjoyment of all unit owners in the COSTA DEL SOL DEVELOPMENT.

AMENDED EXHIBIT 3  
**SURVEY PLOT PLAN**  
**COSTA DEL SOL CONDOMINIUM "T"**  
 BUILDINGS 110, 111, 112 & 113

OFF: 14333PG 318  
REC:

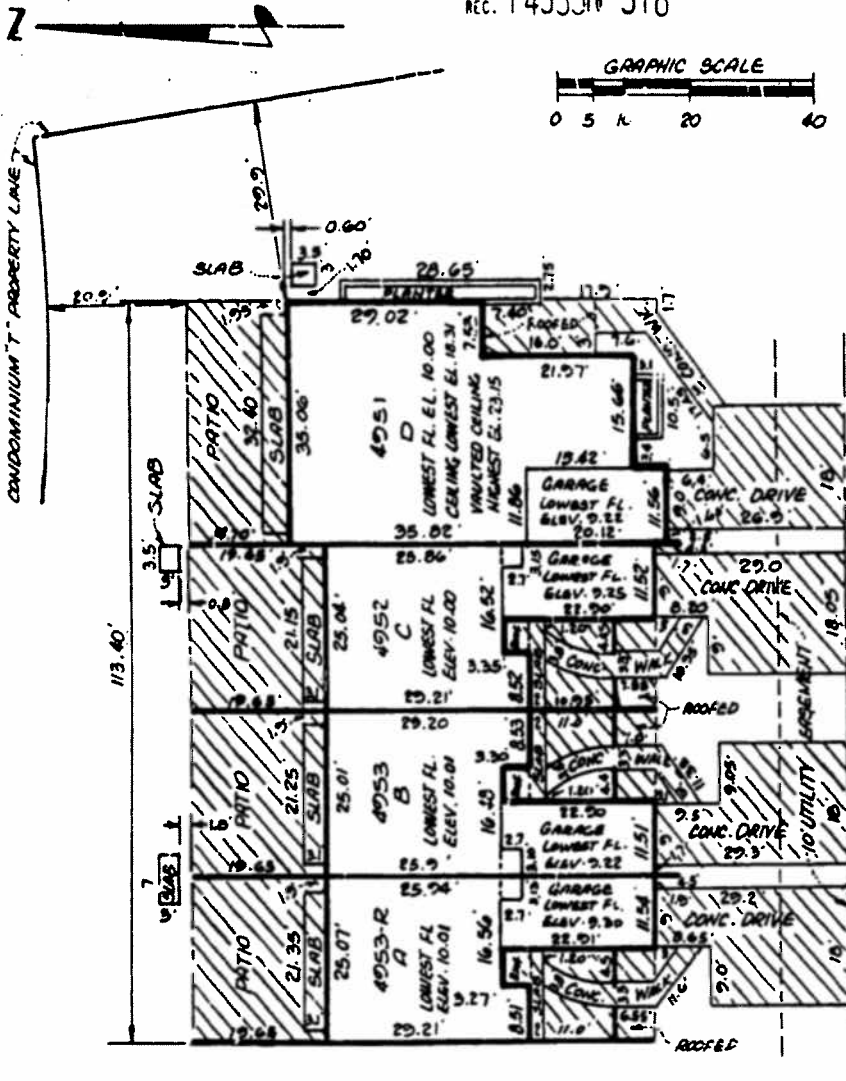

AMENDED EXHIBIT 3  
**COSTA DEL SOL CONDOMINIUM "T"**  
**BUILDING NO. III**  
**FIRST FLOOR PLAN**

DENOTES LIMITED COMMON ELEMENT

**NOTES:**

1. Subject to variations of 0.1: for each unit.
2. All elevations refer to National Geodetic Vertical Datum of 1929.
3. These plans and elevations are compiled from plans prepared by Beilinson Architect, P.A. and supplemented by actual field surveys.

OFF: 14333PG 319  
 REC:

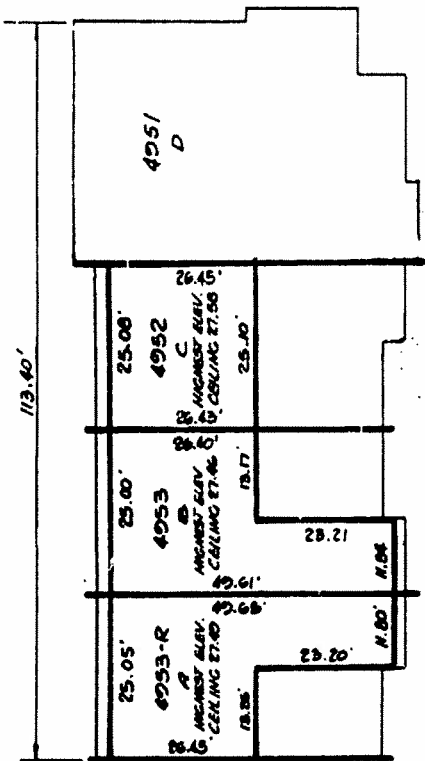
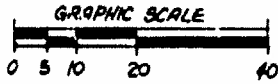

AMENDED EXHIBIT 3  
**COSTA DEL SOL CONDOMINIUM "T"**  
**BUILDING NO. III**  
**SECOND FLOOR PLAN**

**NOTES:**

1. Subject to variations of 0.1' for each unit.
2. All elevations refer to National Geodetic Vertical Datum of 1929.
3. These plans and elevations are compiled from plans prepared by Beilinson Architect, P.A. and supplemented by actual field surveys.

OFF. REC. 143330 320

SURVEYOR'S CERTIFICATE

The undersigned, being a surveyor authorized to practice in the state of Florida, hereby certifies that construction of the improvements within COSTA DEL SOL CONDOMINIUM "T" comprising Building 111 is substantially complete so that the materials comprising this Amended Exhibit 3 to the Declaration of Condominium of COSTA DEL SOL CONDOMINIUM "T" together with the provisions of the Declaration describing the condominium property, is an accurate representation of the location and dimensions of the improvements comprising Building Number 111, and so that the identification, location and the dimensions of the common elements and of each unit within Building Number 111 can be determined from these materials.

The undersigned further certifies that all planned improvements for Building Number 111, including but not limited to, landscaping, utility services and access to the units within Building Number 111 and common element facilities serving Building Number 111, have been substantially completed and meets the minimum technical standards adopted by the Florida Board of Professional Land Surveyors in Chapter 21 HH-6, Florida Administrative Code.

JACK MUELLER & ASSOCIATES, INC.

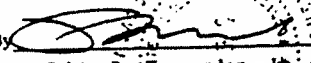
By   
Robin D. Engarden, Jr.  
Reg. Land Surveyor #2294  
State of Florida

Date November 3, 1989

SURVEYOR'S NOTES:

These plans are compiled from plans and data furnished by Lemar Homes, Inc., supplemented by such field survey and measurements as deemed necessary by Jack Mueller & Associates, Inc.

RECORDED IN OFFICIAL RECORDS BOOK  
OF BAKA COUNTY, FLORIDA  
RECORD VERIFIED  
RICHARD P. BRINKER  
CLERK CIRCUIT COURT

CLERK NOTE:  
FOR CONDOMINIUM PLANS SEE OFFICIAL  
RECORDS CONDOMINIUM PLANS BK. 229 PAGE 6

RICHARD P. BRINKER, CLERK  
CIRCUIT & COUNTY COURT  
 D.A.

1989 NOV 14 PM 12:06

89R413185

OFF: 432562908  
REC:

FIRST AMENDMENT TO DECLARATION

COSTA DEL SOL CONDOMINIUM T

THIS FIRST AMENDMENT TO DECLARATION OF COSTA DEL SOL CONDOMINIUM T is made this 10th day of November, 1989, by LENNAR HOMES, INC., a Florida corporation (the "Developer").

W I T N E S S E T H:

A. Developer filed a Declaration of Condominium (the "Declaration") for Costa del Sol Condominium T (the "Condominium"), recorded October 24, 1989 in Official Records Book 14302 at Page 443 of the Public Records of Dade County, Florida.

B. The Surveyor's Certification attached as a portion of Exhibit "3" to the Declaration contains a certification by the Surveyor that only the construction of Building "12" in the Condominium is complete.

C. Developer has now substantially completed Building "110" of the Condominium, and wishes to amend Exhibit "3" to the Declaration to reflect said substantial completion in compliance with Florida Statute 718.104(4)(e).

NOW, THEREFORE, the Developer hereby declares as follows:

1. The Declaration is hereby amended by adding to Exhibit "3" to the Declaration, the Surveyor's Certification attached hereto as Exhibit "A", which certifies that Building "110" of Costa del Sol Condominium T is now substantially completed as such term is defined in Florida Statute 718.104(4)(e).

IN WITNESS WHEREOF, the Developer has executed this Amendment the day and year first above written.

SIGNED, SEALED AND DELIVERED  
IN THE PRESENCE OF:

LENNAR HOMES, INC.

Carol M. Ginter

By: M. E. Saleda  
Vice President

M. J. Watsky

Attest: M. J. Watsky  
Asst. Secretary

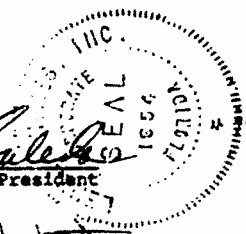

STATE OF FLORIDA  
COUNTY OF DADE

BEFORE ME, the undersigned authority, personally appeared M. E. SALEDA and MORRIS J. WATSKY, Vice President and Assistant Secretary, respectively, of Lennar Homes, Inc., who acknowledged that they were the individuals who executed the above instrument as their free act and deed on behalf of the corporation.

DATED THIS 10th day of November, 1989

Carol M. Ginter  
Notary Public, State of Florida

My Commission Expires:

NOTARY PUBLIC STATE OF FLORIDA  
MY COMMISSION EXP. NOV. 20, 1992  
CONFIDENTIAL GENERAL INS. UND

INSTRUMENT PREPARED BY:  
THIS INSTRUMENT PREPARED BY:  
Morris J. Watsky, Esq.  
Seven Hundred N.W. 107 Ave.  
Miami, Florida 33172

46.50

OFF: 4325PG2909  
REC: 4325PG2909

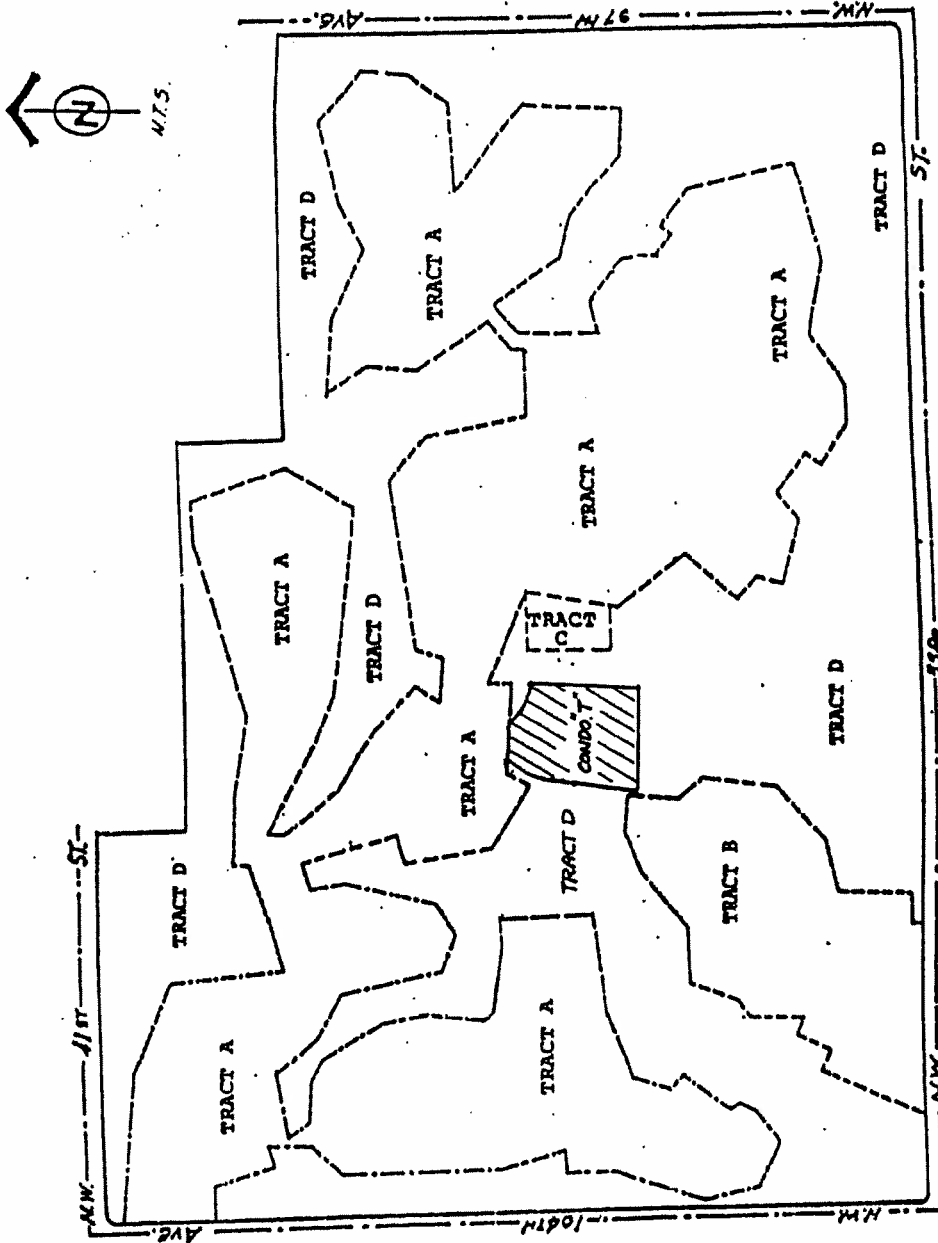

CLERK NOTE:  
FOR DECLARATION OF CONDOMINIUM  
SEE OFFICIAL RECORD BK 4325 PG. 2909

*COSTA DEL SOL TRACT "D" AMENDED  
P.B. 137, P. 71*

AMENDED EXHIBIT 3  
COSTA DEL SOL  
CONDOMINIUM "T" LOCATION PLAN





REC: 432502911

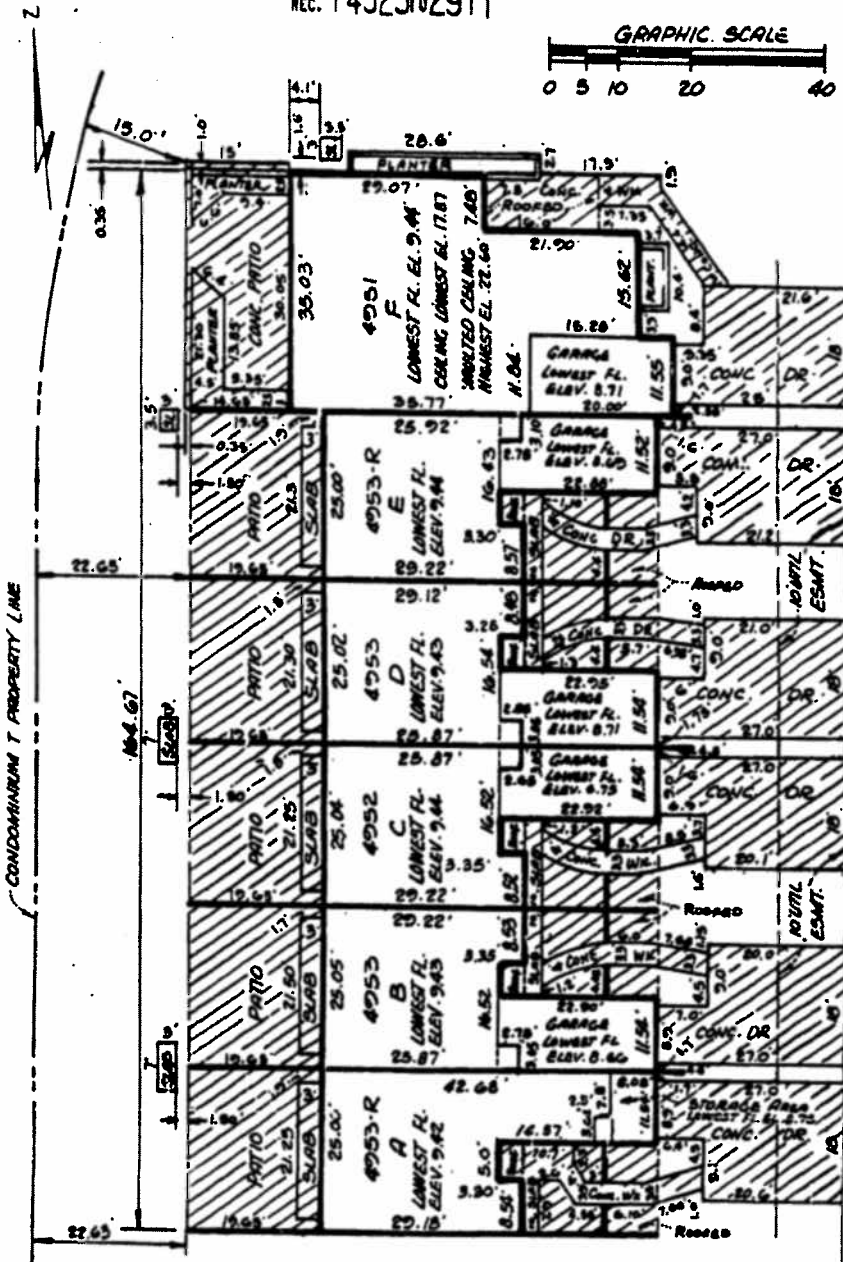

 DENOTES LIMITED COMMON ELEMENT

**NOTES:**

1. Subject to variations of 0.1's for each unit.
2. All elevations refer to National Geodetic Vertical Datum of 1929.
3. These plans and elevations are compiled from plans prepared by B. Ilinson Architect, P.A. and supplemented by actual field surveys.

AMENDED EXHIBIT 3  
**COSTA DEL SOL CONDOMINIUM "T"**  
**BUILDING NO. 110**  
**FIRST FLOOR PLAN**

REC: 14325P62912

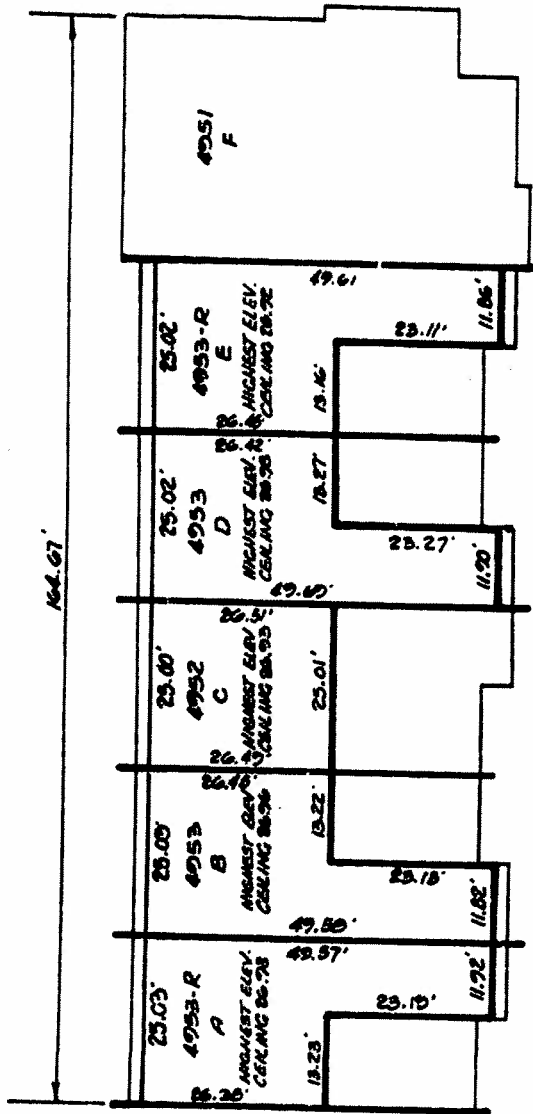

AMENDED EXHIBIT 3  
**COSTA DEL SOL CONDOMINIUM "T"**  
**BUILDING NO. 110**  
**SECOND FLOOR PLAN**

**NOTES:**

1. Subject to variations of 0.1' for each unit.
2. All elevations refer to National Geodetic Vertical Datum of 1929.
3. These plans and elevations are compiled from plans prepared by Bellinson Architect, P.A. and supplemented by actual field surveys.

REF: 14325PG2913

SURVEYOR'S CERTIFICATE

The undersigned, being a surveyor authorized to practice in the state of Florida, hereby certifies that construction of the improvements within COSTA DEL SOL CONDOMINIUM "T" comprising Building 110 is substantially complete so that the materials comprising this Amended Exhibit 3 to the Declaration of Condominium of COSTA DEL SOL CONDOMINIUM "T" together with the provisions of the Declaration describing the condominium property, is an accurate representation of the location and dimensions of the improvements comprising Building Number 110, and so that the identification, location and the dimensions of the common elements and of each unit within Building Number 110 can be determined from these materials.

The undersigned further certifies that all planned improvements for Building Number 110, including but not limited to, landscaping, utility services and access to the units within Building Number 110 and common element facilities serving Building Number 110, have been substantially completed and meets the minimum technical standards adopted by the Florida Board of Professional Land Surveyors in Chapter 21 HH-6, Florida Administrative Code.

JACK MUELLER & ASSOCIATES, INC.

By   
Robin D. Tesgard, Jr.  
Reg. Land Surveyor #2354  
State of Florida  
Date October 26, 1999

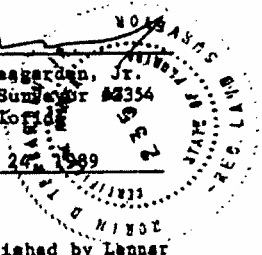

SURVEYOR'S NOTES:

These plans are compiled from plans and data furnished by Lennar Homes, Inc., supplemented by such field survey and measurements as deemed necessary by Jack Mueller & Associates, Inc.

REC'D TO IN OFFICIAL RECORDS BOOK  
OF DADE COUNTY, FLORIDA  
RECORD NUMBER  
RICHARD P. BRINKER  
CLERK HAZARD COURT

CLERK NOTE:  
FOR CONDOMINIUM PLANS SEE OFFICIAL  
RECORDS CONDOMINIUM PLANS BK. 229 PAGE 3

RICHARD P. BRINKER, CLERK  
CIRCUIT & COUNTY COURT  
BY  D. C.

REC: 14302M 443

DECLARATION OF  
COSTA DEL SOL CONDOMINIUM T

LENNAR HOMES, INC., a Florida corporation (hereinafter called the "Developer") does hereby declare as follows:

1. Introduction and Submission:

§1.1 The Land. The Developer owns the fee title to certain real property located in Dade County, Florida, as more particularly described in Exhibit 1 attached hereto (the "Land").

§1.2 Submission Statement. The Developer hereby submits the Land and, except as otherwise provided herein, all improvements erected or to be erected thereon, all easements, rights and appurtenances belonging thereto, and all other property, real, personal or mixed, intended for use in connection therewith, less and except the Central System as defined in this Declaration, to the condominium form of ownership and use in the manner provided by the Florida Condominium Act as it exists on the date hereof.

§1.3 Name. The name by which this condominium is to be identified is: Costa del Sol Condominium T (hereinafter called the "Condominium").

2. Definitions. The following terms which are used in this Declaration and in its exhibits, and as they may hereafter be amended, shall have the meaning described to them in this Section, except where the context clearly indicates a different meaning:

§2.1 "Act" means the Condominium Act (Chapter 719 of the Florida Statutes) as it exists on the date hereof and as hereafter renumbered.

§2.2 "Articles" means the Articles of Incorporation of the Association.

§2.3 "Assessment" means a share of the funds required for the payment of Common Expenses which, from time to time, is assessed against the Unit Owner.

§2.4 "Association" means Costa del Sol Condominium T Association, Inc., a Florida corporation not for profit, the entity responsible for the operation of the Condominium.

§2.5 "Association No. 2" means the Costa del Sol Property Owners Association No. 2, Inc., a Florida corporation not for profit, the entity responsible for the operation of the Common Areas.

§2.6 "Association Property" means that property, real and personal, in which title or ownership is vested in the Association for the use and benefit of its members.

§2.7 "Building" means the structure or structures in which the Units are located on the Condominium Property.

§2.8 "By-Laws" means the By-Laws of the Association.

§2.9 "Common Areas" mean the property described in the Original Declaration as Common Areas.

§2.10 "Common Areas Declaration" means the Declaration of Covenants, Restrictions and Easements for the Common Areas.

ESR ET 24 PM 3 15

BSR326191

REF: 14302PG 444

§2.11 "Common Elements" mean and include:

- (a) The portions of the Condominium Property which are not included within the Units;
- (b) Easements through Units for conduits, ducts, plumbing, wiring and other facilities for the furnishing of utility and other services to Units and Common Elements;
- (c) An easement of support in every portion of the Unit which contributes to the support of the Building;
- (d) The property and installations required for the furnishing of utilities and other services to more than one Unit or to the Common Elements;
- (e) Any other parts of the Condominium Property designated as Common Elements in the Declaration;
- (f) Common Elements includes Limited Common Elements unless the context otherwise requires.

§2.12 "Common Expenses" means all expenses incurred and Assessments (and Special Assessments levied against all of the Units of the Condominium) by the Association for the Condominium.

§2.13 "Common Surplus" means the excess of all receipts of the Association collected on behalf of the Condominium, including but not limited to, Assessments, Special Assessments, rents, profits and revenues on account of the Common Elements, above the amount of Common Expenses.

§2.14 "Condominium Parcel" means a Unit together with the undivided share in the Common Elements which is appurtenant to said Unit, and when the context permits, the term includes all other appurtenances to the Unit.

§2.15 "Condominium Property" means the land and personal property that are subject to condominium ownership under the Declaration, all improvements on the land, and all easements and rights appurtenant thereto intended for use in connection with the Condominium.

§2.16 "Costa del Sol Project" refers to the entire group of Condominiums which the Original Developer and the Successor Developer caused to be constructed and the Developer intends to construct upon the Costa del Sol Project Lands.

§2.17 "Costa del Sol Project Lands" means and refers to the land upon which the Costa del Sol Project is to be located and constructed, which lands are delineated on the Site Plan attached to the Prospectus as Exhibit 1. With the exception of this Condominium and the existing condominiums created by Developer, the Costa del Sol Project - Stage 1 to be constructed on the Costa del Sol Project Lands is a projected plan of development only and nothing herein contained shall be construed as making it obligatory upon the Developer to construct said project or in accordance with any particular plan of development.

§2.18 "Costa del Sol Project - Stage 1" means and refers to the developed portions of the Costa del Sol Project consisting of Condominiums Nos. 1, 2, 3 and 4.

§2.19 "Costa del Sol Project - Stage 2", except as provided in Section 2.16 above, means the undeveloped portions of the Costa del Sol Project which is zoned or usable for residential purposes.

§2.20 "County" shall mean Brevard County, State of Florida.

§2.21 "Declaration" or "Declaration of Condominium" means the instrument

REF: 1430276 445

- or instruments, which the Condominium will be created.
- §2.22 "Developer" means Lennar Homes, Inc., a Florida corporation, its successors and such of its assigns as to which the rights of Developer hereunder are specifically assigned. Developer may assign only a portion of its rights hereunder, or all or a portion of such rights in connection with appropriate portions of the Condominium. In the event of such partial assignment, the assignee shall not be deemed the Developer, but may exercise such rights of the Developer specifically assigned to it. Any such assignment may be made on a non-exclusive basis.
- §2.23 "Improvements" mean all structures and artificial changes to the natural environment (exclusive of landscaping) on the Condominium Property, including but not limited to, the Building or Buildings.
- §2.24 "Institutional First Mortgagee" means a bank, savings and loan association, insurance company, mortgage banker, real estate or mortgage investment trust, pension fund, Developer, GNMA, FNMA, FHLMC, VA, FHA, or any other lender, or its loan correspondent or agency of the United States Government, holding, guaranteeing or insuring a first mortgage on a Unit or Units.
- §2.25 "Limited Common Elements" mean and include those Common Elements which are reserved for the use of a certain Unit or Units to the exclusion of all other Units as specified in this Declaration.
- §2.26 "Management Contract" means and refers to that certain agreement, which provides for the management of the Condominium Property.
- §2.27 "Management Firm" means and refers to the corporation, its successors and assigns, identified as the Management Firm in the Management Contract. The Management Firm shall be responsible for the management of the Condominium Property as provided in the Management Contract.
- §2.28 "Original Association" or "Association No. 1" means Costa del Sol Association, Inc., a Florida corporation not for profit, the entity responsible for the operation and management of the Condominiums and Common Areas.
- §2.29 "Original Declaration" means the Declaration of Restrictions and Maintenance Covenants for "Costa del Sol" and amendments thereto.
- §2.30 "Original Developer" means Costa del Sol Golf & Racquet Club, Inc., a Florida corporation.
- §2.31 "Primary Institutional First Mortgagee" means the Institutional First Mortgagee which owns at any time large mortgages encumbering Units which secure a greater aggregate indebtedness than is owed to any other Institutional First Mortgagee.
- §2.32 "Special Assessment" means any assessment levied against Unit Owners other than the Assessment required by a budget adopted annually.
- §2.33 "Successor Developer" means ERI Properties, Inc., a New York corporation.
- §2.34 "Unit" means a part of the Condominium Property which is subject to exclusive ownership.
- §2.35 "Unit Owner" or "Owner of a Unit" means the Owner of a Condominium Parcel.

REC: 14302PG 446

§2.36 "Voting Certificate" means a document which designates one of the record title owners, or the corporate partnership, or entity representative who is authorized to vote on behalf of a Unit owned by more than one owner or by any entity.

§2.37 "Voting Interest" means the voting rights distributed to the Association members pursuant to the Act and Section 5 of this Declaration.

3. Description of Condominium.

§3.1 Identification of Units. The Land has or will have constructed thereon four (4) Buildings containing a total of twenty-two (22) Units. Each such Unit is identified by a separate numerical or alpha-numerical designation. The designation of each of such Units is set forth on Exhibit 3 attached hereto. Exhibit 3, together with this Declaration is sufficient in detail to identify the Common Elements and each Unit and their relative locations and approximate dimensions. There shall pass with a Unit, as appurtenances thereto: (a) an undivided share in the Common Elements and Common Surplus; (b) the exclusive right to use such portion of the Common Elements as may be provided in this Declaration; (c) an exclusive easement for the use of the airspace occupied by the Unit as it exists at any particular time and as the Unit may lawfully be altered or reconstructed from time to time, provided that an easement in airspace which is vacated shall be terminated automatically; (d) membership in the Association designated in this Declaration with the full voting rights appertaining thereto and (e) other appurtenances as may be provided in this Declaration. Time-share estates will not be created with respect to any Unit in the Condominium.

§3.2 Unit Boundaries. Each Unit shall include that part of the Building containing the Unit that lies within the boundaries of the Unit, which boundaries are as follows:

(a) Upper and lower boundaries. The upper and lower boundaries of the portion of the one-story Unit shall be the following boundaries extended to an intersection with the perimeteral boundaries:

(i) Upper boundaries. The horizontal plane of the unfinished lower surface of the unfinished ceiling.

(ii) Lower boundaries. The horizontal plane of the unfinished upper surface of the floor.

(b) Upper and lower boundaries. The upper and lower boundaries of the two-story Unit shall be the following boundaries extended to an intersection with the perimeteral boundaries:

FIRST FLOOR

(i) Upper boundaries. The horizontal plane of the unfinished lower surface of the ceiling.

(ii) Lower boundaries. The horizontal plane of the unfinished upper surface of the floor.

SECOND FLOOR

(i) Upper boundaries. The horizontal plane of the unfinished lower surface of the ceiling.

(ii) Lower boundaries. The horizontal plane of the unfinished upper surface of the floor.

(c) Perimeteral boundaries. The perimeteral boundaries of the Unit shall be the vertical planes of the unfinished



OFF: 1430200 447  
REC: 1430200 447

interior of the walls bounding the Unit extended to intersections with each other and with the upper and lower boundaries.

**§3.3 Limited Common Elements.** Each Unit shall have, as Limited Common Elements appurtenant thereto:

- (a) Patios, Yards, Terraces. Any patio, terrace or yard which is enclosed on at least three (3) sides and as to which direct and exclusive access shall be afforded to any particular Unit shall be a Limited Common Element of such Unit.
- (b) Automobile Parking Spaces. The automobile parking spaces shall be Limited Common Elements of the Units with respect to which the space or spaces are assigned.
  - (i) Assigned Spaces for Units. Each Unit shall be entitled to the exclusive use of two (2) parking spaces which the Developer shall assign to the Unit at closing. Thereafter, the Board of Directors of the Association shall be empowered to change said assignments, provided the Unit Owners affected by such change consent thereto, and provided that no change may be made without the prior consent of the Developer so long as the Developer owns any Units. Assignment (or changes in assignments) made pursuant to this Subsection (i) shall be in writing (but not recorded in the Public Records) with a copy furnished to the Board of Directors.
  - (ii) Nature of Assignment. An assignment of any parking space grants only the exclusive use thereof as a Limited Common Element appurtenant to the particular Unit and does not convey any title thereto. Any transfer, or subsequent assignment as contemplated above, shall operate to transfer only the exclusive use of such space(s). Except as provided specifically in Subsection (i) above, the space(s) assigned to the Unit pursuant to such Subsection (i) shall not be assignable except together with the applicable Unit and the form of Assignment given by the Developer shall so note. In the event a Unit Owner leaves his space(s) vacant while he is away from the Unit for an extended period, the Association shall be entitled to allow other persons to use said space(s) while they remain vacant.

**§3.4 EASEMENTS.** The following easements are hereby created in addition to any easements created under the Act:

- (a) Support. Each Unit shall have an easement of support and, if necessary and shall be subject to an easement of support and necessary in favor of all other Units and the Common Elements.
- (b) Utility and Other Services; Drainage. Easements are reserved under, through and over the Condominium Property as may be required from time to time for utility and other services and drainage in order to serve the Condominium. A Unit Owner shall do nothing within or outside his Unit that interferes with or impairs, or may interfere with or impair, the provision of such utility or other services or drainage facilities or the use of these easements. The Board of Directors of the Association or its designee shall inspect same, to maintain, repair or replace the pipes, wires, ducts, vents, cables, conduits and other utility, service and drainage facilities and Common Elements contained in the Unit or elsewhere in the Condominium Property.

OFF. REC. 43C210 448

- (c) Encroachments. If (a) any portion of the Common Elements encroaches upon any Unit; (b) any Unit encroaches upon any other Unit or upon any portion of the Common Elements; or (c) any encroachment shall hereafter occur as a result of (i) construction of the Improvements; (ii) settling or shifting of the Improvements; (iii) any alteration or repair to the Common Elements made by or with the consent of the Association, or (iv) any repair or restoration of the Improvements (or any portion thereof) or any Unit after damage by fire or other casualty or any taking by condemnation or eminent domain proceedings of all or any portion of any Unit or the Common Elements, then, in any such event, a valid easement shall exist for such encroachment and for the maintenance of the same so long as the Improvements shall stand.
- (d) Ingress and Egress. A non-exclusive easement in favor of each Unit Owner and occupant, their respective guests and invitees, shall exist for pedestrian traffic over, through and across sidewalks, streets, paths, walks and other portions of the Common Elements as from time to time may be intended and designated for such purpose and use (if any); and for vehicular and pedestrian traffic over, through and across such portions of the Common Elements as from time to time may be paved and intended for such purposes (if any). None of the easements specified in this Subparagraph (d) shall be encumbered by any leasehold or lien other than those on the Condominium Parcels. Any such lien encumbering such easements (other than those on Condominium Parcels) shall automatically be subordinate to, the rights of Unit Owners with respect to such easements.
- (e) Construction; Maintenance. The Developer (including the designers, contractors, successors and assigns) shall have the right, in its and their sole discretion, from time to time, to enter the Condominium Property and take all other action necessary or convenient for the purpose of completing the construction thereof, of any Improvements or Units located or to be located thereon, and for repair, replacement and maintenance purposes where the Association fails to do so, provided such activity does not prevent or unreasonably interfere with the use or enjoyment by the Unit Owners of the Condominium Property.
- (f) Sale Activity. For as long as there are any unsold Units, the Developer, its designers, successors and assigns, shall have the right to use any such Units and parts of the Common Elements for model apartments and sales offices, to show model apartments and the Common Elements to prospective purchasers and tenants of the Units, and to erect on the Condominium Property signs and other promotional material or advertise Units and certain limited Common Elements for sale or lease.
- (g) Developer's Warranty. For as long as Developer is liable under the terms of its Warranty in favor of the Unit Owners and Association, Developer, including its designers and contractors shall have the right, in its and their sole discretion, from time to time, to enter the Condominium Property or any improvements or Units located thereon, for repair or replacement purposes and take all other action necessary or convenient for the purpose of fulfilling its obligations under the Warranty.
- (h) Governmental Personnel. A right of entry over, through and across the Common Elements is hereby granted to Law

OFF. REC. 1430276 449

enforcement officers, fire and rescue personnel and sanitation personnel as needed to carry out their duties, including enforcement of cleared emergency vehicle access.

- (i) Additional Easements. The Developer (so long as it owns any Units) and the Association, on their behalf and on behalf of all Unit Owners (each of whom hereby appoints the Developer and the Association as their attorney-in-fact for this purpose), each shall have the right to grant such additional electric, gas, other utility or service or other easements, or relocate any existing easements or drainage facilities, in any portion of the Condominium Property, and to grant access easements or relocate any existing access easements in any portion of the Condominium Property, as the Developer or the Association shall deem necessary or desirable for the proper operations and maintenance of the Improvements, or any portion thereof, or for the general health or welfare of the Unit Owners, or for the purpose of carrying out any provisions of this Declaration or otherwise, provided that such easements or the relocation of existing easements will not prevent or unreasonably interfere with the reasonable use of the Units for dwelling purposes. The Association, subject to the prior consent of the Developer, which consent shall be required until December 31, 1999 or until Developer has conveyed title to the last Condominium Unit to be built in Costa del Sol Project - Stage 2, or such earlier time as may be determined in the sole discretion of Developer, has the authority without the joinder of any Unit Owners, to grant, modify or move any easement, subject to the provisions of the easement, if the easement constitutes part of or crosses the Common Elements.
4. Restraining Upon Separation and Partition of Common Elements. The undivided share in the Common Elements and Common Surplus which is appurtenant to a Unit, an exclusive easement for the use of the airspace occupied by the Unit as it exists at any particular time and as the Unit may lawfully be altered or reconstructed from time to time, membership in the Association designated in this Declaration, with the full voting rights appurtenant thereto, and except as provided herein, the exclusive right to use all appropriate appurtenant limited Common Elements, shall not be separated and shall pass with the title of the Unit, whether or not separately described. All of these afore-described appurtenances to a Unit cannot be conveyed or enumerated except together with the Unit. The respective shares in the Common Elements appurtenant to Units shall remain undivided, and no action for partition of the Common Elements, the Condominium Property, or any part thereof, shall lie, except as provided herein with respect to termination of the Condominium.
5. Ownership of Common Elements and Common Surplus and Share of Common Expenses; Voting Rights.
- 55.1 Percentage Ownership and Shares. The undivided percentage interest in the Common Elements and Common Surplus, and the percentage share of the Common Expenses appurtenant to each Unit, is set forth in Exhibit C annexed hereto.
- 55.2 Voting. Each Unit shall be entitled to one vote to be cast by its Owner in accordance with the provisions of the By-Laws and Articles. Each Unit Owner shall be a member of the Association.
6. Amendments. Except as elsewhere provided herein, amendments may be effected as follows:
- 66.1 By the Association. Notice of the subject matter of a proposed amendment shall be included in the notice of any

OFF.  
REC. 1430270 450

meeting at which a proposed amendment is to be considered. A resolution for the adoption of a proposed amendment may be proposed either by a majority of the Board of Directors of the Association or by not less than one-third (1/3) of the voting interests of the members of the Association. Directors and members not present in person or by proxy at the meeting considering the amendment may express their approval in writing, provided that such approval is delivered to the Secretary at or prior to the meeting. Except as elsewhere provided, approvals must be by affirmative vote of:

- (a) Unit Owners owning in excess of 50% of the voting interests represented at any meeting at which a quorum has been attained and by not less than 66-2/3% of the Board of Directors of the Association; or,
- (b) Unit Owners owning not less than 80% of the voting interests represented at any meeting at which a quorum has been attained; or,
- (c) 100% of the Board of Directors; or
- (d) Not less than 50% of the entire membership of the Board of Directors in the case of amendments to the section hereof entitled "Insurance" or other sections that are reasonably required by insurers or the Primary Institutional First Mortgagee.

§6.2 By the Developer. The Developer, during the time it is in control of the Board of Directors of the Association, may amend the Declaration, the Articles of Incorporation or the By-Laws of the Association to correct an omission or error, or effect any other amendment, except that this procedure for amendment cannot be used if such an amendment would, in the reasonable opinion of the Developer, materially adversely affect substantial property rights of Unit Owners, unless the affected Unit Owners consent in writing. Developer, in Section 6.2 hereof, has specifically reserved the right to change the size and or number of Developer owned Units so long as the percentage interest in the Common Elements and share of the Common Surplus and Common Expenses of non-Developer owned Units do not change. Such a change will not materially adversely affect the property rights of Unit Owners, other than the Developer and, if necessary, the Developer may amend this Declaration and the Exhibits thereto from time to time without the consent of any other Unit Owners to evidence the change in size and or number of Developer owned Units. The execution and recording of any amendment by the Developer pursuant hereto shall be conclusive evidence that the amendment does not materially adversely affect substantial property rights of Unit Owners who did not join in or consent to such execution, and any such amendment shall be effective as provided below unless subsequently rescinded.

§6.3 Execution and Recording. An amendment, other than amendments made by the Developer alone pursuant to the Act or this Declaration, shall be evidenced by a certificate of the Association which shall include recording data identifying the Declaration and shall be executed in the form required for the execution of a Deed. Amendments by the Developer must be evidenced in writing, but a certificate of the Association is not required. An amendment of the Declaration is effective when properly recorded in the Public Records of the County.

§6.4 Procedure. No provision of this Declaration shall be revised or amended by reference to its title or number only. Proposals to amend existing provisions of this Declaration shall contain the full text of the provision to be amended; new words shall be

OFF. REC. 14302PG 451

inserted in the text underlined; and words to be deleted shall be lined through with hyphens. However, if the proposed change is so extensive that this procedure would hinder, rather than assist, the understanding of the proposed amendment, it is not necessary to use underlining and hyphens as indicators of words added or deleted, but, instead, a notation must be inserted immediately preceding the proposed amendment in substantially the following language: "Substantial rewording of declaration. See provision .... for present text". Nonmaterial errors or omissions in the amendment process shall not invalidate an otherwise properly promulgated amendment.

§6.5 Proviso. Unless otherwise provided specifically to the contrary in this Declaration, no amendment shall change the configuration or size of any Unit in any material fashion, materially alter or modify the appurtenances to any Unit; or change the percentage by which the Owner of a Unit shares the Common Expenses and owns the Common Elements and Common Surplus, unless the record Owner(s) thereof and all record owners of mortgages or other liens thereon shall join in the execution of the amendment. No amendment may be adopted which would eliminate, modify, prejudice, abridge or otherwise adversely affect any rights, benefits, privileges or priorities granted or reserved to the Developer or mortgagees of Units without the consent of said Developer or mortgagees in each instance; or shall an amendment make any change in the sections hereof entitled "Insurance", "Reconstruction or Repair after Casualty" or "Condemnation" unless all Institutional First Mortgagees whose mortgages are of record shall join in the amendment.

7. Maintenance and Repairs.

§7.1 Units. All maintenance, repairs and replacements of, in or to any Unit and Limited Common Elements appurtenant thereto, whether structural or nonstructural, ordinary or extraordinary, including, without limitation, maintenance, repair and replacement of screens, windows, the interior side of the entrance door and all other doors within or affording access to a Unit, and the electrical, plumbing, heating and air-conditioning equipment, fixtures and outlets, if any, within the Unit or the Limited Common Elements or belonging to the Unit Owner, shall be performed by the Owner of such Unit at the Unit Owner's sole cost and expense, except as otherwise expressly provided to the contrary herein, and shall be made in accordance with the original plans and specifications therefor or as otherwise directed by the Association.

§7.2 Common Elements. Except to the extent it expressly provided to the contrary herein, or in proceeds of insurance are made available therefor, all maintenance, repairs and replacements in or to the Common Elements (other than Limited Common Elements as provided above) shall be performed by the Association and the cost and expense thereof shall be charged to all Unit Owners as a Common Expense, except to the extent arising from or necessitated by the negligence, misuse or neglect of specific Unit Owners, in which case such cost and expense shall be paid solely by such Unit Owners.

§7.3 Specific Unit Owner Responsibility. The obligation to maintain and repair the following specific items shall be the responsibility of the Unit Owners, individually, and not the Association, without regard to whether such items are included within the boundaries of the Units, are Limited Common Elements or the Common Elements (other than Limited Common Elements).

- a. Where a Limited Common Element consists of a balcony or patio, the Unit Owner who has the right to the exclusive use of said balcony or patio shall be responsible for the maintenance, care and preservation of the paint and surface of the interior parapet walls, including floor and ceiling, within

REF: 14302PG 452

said area, if any, and the frame and/or sliding glass door(s) in or other portions of the entrance way(s) of said area, if any, and the wiring, electrical outlet(s) and fixtures, if any, thereon, if any, and the replacement of light bulbs, if any.

- (b) Storage space and/or utility space, if applicable.
- (c) Air conditioner condensing unit, if applicable.

**57.4 Developer's Lien.** In the event the Association fails to maintain, replace or repair as herein provided, upon thirty (30) days notice to the Association, the Developer or its designee shall have the right, without being obligated to do so, to enter upon the Condominium Property, including, without limitation, interest, court costs and reasonable attorneys' fees and appellate attorneys' fees incurred by the Developer in collecting the sums expended by it. The aforesaid lien may be foreclosed in the same manner as mortgages or statutory liens are foreclosed in Florida. In the event of an emergency situation, threatening the health and welfare of the residents, the Developer may immediately enter upon the Condominium Property and cause such maintenance replacements or repairs to be made forthwith and without the requirement of any prior notice thereof, and the Developer shall have an enforceable lien upon the Condominium Property as aforesaid.

**57.5 Association's Right of Access to Units.** The Association has the irrevocable right of access to each Unit during reasonable hours, when necessary for the maintenance, repair, or replacement of any Common Elements, or for making emergency repairs which are necessary to prevent damage to the Common Elements or to another Unit or Units.

**8. Additions, Alterations or Improvements by the Association.** Whenever, in the judgment of the Board of Directors, the Common Elements or any part thereof shall require capital additions, alterations or improvements (as distinguished from repairs and replacements costing in excess of \$5,000.00 in the aggregate in any calendar year, the Association may proceed with such additions, alterations or improvements only if the making of such additions, alterations or improvements shall have been approved by a majority of the voting interests of the Units represented at a meeting at which a quorum is attained. Any such additions, alterations or improvements to such Common Elements or any part thereof costing in the aggregate of \$5,000.00 or less in a calendar year may be made by the Association without approval of the Unit Owners. The cost and expense of any such additions, alterations or improvements to such Common Elements shall constitute a part of the Common Expenses and shall be assessed to the Unit Owners as Common Expenses.

**9. Additions, Alterations or Improvements by Unit Owners.**

**99.1 Consent of the Board of Directors.** No Unit Owner shall make any addition, alteration or improvement in or to the Common Elements, his Unit or any Limited Common Elements without the prior written consent of the Board of Directors. The Board shall have the obligation to answer any written request by a Unit Owner for approval of such an addition, alteration or improvement in such Unit Owner's Unit or Limited Common Elements within thirty (30) days after such request and all additional information requested is received, and the failure to do so within the stipulated time shall constitute the Board's consent. The proposed additions, alterations and improvements by the Unit Owners shall be made in compliance with all laws, rules, ordinances and regulations of all governmental authorities having jurisdiction and with any conditions imposed by the Association with respect to design, structural integrity, aesthetic appeal, construction details, lien protection or otherwise.

OFF: 1430298 453

A Unit Owner making or causing to be made any such additions, alterations or improvements agrees, and shall be deemed to have agreed, for such Owner and his heirs, personal representatives, successors and assigns, as appropriate, to hold the Association, all other Unit Owners harmless from any liability or damage to the Condominium Property and expenses arising therefrom, and shall be solely responsible for the maintenance, repair and insurance from and after that date of installation or construction thereof as may be required by the Association.

- 59.2 Additions, Alterations or Improvements by Developer. The foregoing restrictions of this Section 9 shall not apply to Developer-owned Units. The Developer shall have the additional right, without the consent or approval of the Board of Directors or other Unit Owners, to (a) make alterations, additions or improvements, structural and nonstructural, interior and exterior, ordinary and extraordinary, in, to and upon any Unit owned by it (including, without limitation, the removal of walls, floors, ceilings and other structural portions of the Improvements).
10. Changes in Developer-Owned Units. Without limiting the generality of the provisions of Subsection 9.2 above, the Developer shall have the right, without the vote or consent of the Association or Unit Owners, to (i) make alterations, additions or improvements in, to and upon Units owned by the Developer, whether structural or nonstructural, interior or exterior, ordinary or extraordinary; (ii) change the layout or number of rooms in any Developer-owned Units; (iii) change the size and/or number of Developer-owned Units by subdividing one or more Developer-owned Units (including those resulting from such subdivision or otherwise) into one or more Units or otherwise; and (iv) reapportion among the Developer-owned Units so affected by such change in size or number, their appurtenant interests in the Common Elements and share of the Common Surplus and Common Expenses; provided, however, that the percentage interest in the Common Elements and share of the Common Surplus and Common Expenses of any Units other than Developer-owned Units, shall not be changed by reason thereof unless the Owners of such Units shall consent thereto, and, provided further that Developer shall comply with all laws, ordinances and regulations of all governmental authorities having jurisdiction in so doing. In making the above alterations, additions and improvements, the Developer may relocate and alter Common Elements adjacent to such Units provided that such relocation and alteration does not materially adversely affect the market value or ordinary use of Units owned by Unit Owners other than the Developer. Any amendments to this Declaration required by actions taken pursuant to this Section 10 may be effected by the Developer alone. Without limiting the generality of Section 6.5 hereof, the provisions of this Section may not be added to, amended or deleted without the prior written consent of the Developer.
11. Operation of the Condominium by the Association; Powers and Duties. The Association shall be the entity responsible for the operation of the Condominium. The powers and duties of the Association shall include those set forth in the Articles of Incorporation and By-laws of the Association (respectively, Exhibits 4 and 5 annexed hereto), as amended from time to time. In addition, the Association shall have all the powers and duties set forth in the Act, as well as all powers and duties granted to or imposed upon it by this Declaration, including, without limitation:
- (a) The Association has the irrevocable right of access to each Unit during reasonable hours when necessary for the maintenance, repair or replacement of any Common Elements or for making emergency repairs which are necessary to prevent damage to the Common Elements or to any other Unit or Units. The Association has the right to determine compliance with

OFF. REC. 14302PG 454

- the terms and provisions of this Declaration, the exhibits annexed hereto, and the rules and regulations adopted pursuant to such documents, as the same may be amended from time to time.
- (b) The power to make and collect Assessments and Special Assessments and other charges and surcharges against Unit Owners and to lease, maintain, repair and replace the Common Elements.
- (c) The duty to maintain accounting records according to good accounting practices, which shall be open to inspection by Unit Owners or their authorized representatives at reasonable times.
- (d) To contract for the management and maintenance of the Condominium Property and to authorize a management agent (which may be an affiliate of the Developer) to assist the Association in carrying out its powers and duties by performing such functions as the submission of proposals, collection of Assessments and Special Assessments, preparation of records, enforcement of rules and maintenance, repairs and replacement of the Common Elements with funds as shall be made available by the Association for such purposes. The Association and its officers shall, however, retain at all times the powers and duties granted by the Condominium documents and the Condominium Act, including but not limited to the making of Assessments, Special Assessments, promulgation of rules and execution of contracts on behalf of the Association.
- (e) The power to borrow money, execute promissory notes and other evidences of indebtedness and to give as security therefor mortgages and security interests in property owned by the Association, provided that such actions are approved by a majority of the entire membership of the Board of Directors and of the voting interests of the Units represented at a meeting at which a quorum has been attained, or by such greater percentage of the Board or voting interests of the Unit Owners as may be specified in the By-Laws with respect to certain borrowings.
- (f) Subsequent to the recording of this Declaration, the Association, when authorized by a majority of the voting interests of the Units represented at a meeting at which a quorum has been attained, shall have the power to acquire and enter into agreements for the acquisition of fee interests, leaseholds, memberships and other possessory or use interests in lands or facilities, including, but not limited to, country clubs, golf courses, marinas and other recreational facilities, whether or not contiguous to the lands of the Condominium intended or provided for the use or benefit of the Unit Owners (whether or not on an exclusive basis). The expenses of ownership (including the expense of making and carrying any mortgage related to such ownership, rental, membership fees, operation, replacements and other expenses and undertakings in connection therewith shall be Common Expenses. No actions authorized hereunder, however, may be taken without prior consent of Developer as long as the Developer owns any Units.
- (g) The power to adopt and amend the rules and regulations governing the details of the operation and use of the Condominium Property.
- (h) The power to levy reasonable fines against a Unit for failure of the Owner or its occupant, licensee or invitee to comply with any provision of this Declaration, the By-Laws or the rules and regulations.



OFF: 14302PG 455

- (i) All of the powers which a corporation not for profit in the State of Florida may exercise.

In the event of conflict between the powers and duties of the Association or otherwise, the Declaration shall take precedence over the Articles, By-Laws and applicable rules and regulations; the Articles shall take precedence over the By-Laws and applicable rules and regulations; and the By-Laws shall take precedence over applicable rules and regulations, all as amended from time to time.

**§11.1 Limitation Upon Liability of Association.**

Notwithstanding the duty of the Association to maintain and repair parts of the Condominium Property, the Association shall not be liable to Unit Owners for injury or damage, other than for the cost of maintenance and repair caused by any latent condition of the Condominium Property.

**§11.2 Restraint Upon Assignment of Shares in Assets.** The share of a Unit Owner in the funds and assets of the Association cannot be assigned, hypothecated or transferred in any manner except as an appurtenance to his Unit.

**§11.3 Approval or Disapproval of Matters.** Whenever the decision of a Unit Owner is required upon any matter, whether or not the subject of an Association meeting, that decision shall be expressed by the same person who would cast the vote for the Unit if at an Association meeting, unless the joinder of record Owners is specifically required by the Declaration or by law.

**§11.4 Acts of the Association.** Unless the approval or action of Unit Owners and/or a certain specific percentage of the Board of Directors of the Association is specifically required in this Declaration, the Articles or By-Laws of the Association, applicable rules and regulations or applicable law, all approvals or actions required or permitted to be given or taken by the Association shall be given or taken by the Board of Directors, without the consent of Unit Owners, and the Board may so approve and act through the proper officers of the Association without a specific resolution. When an approval or action of the Association is permitted to be given or taken hereunder or thereunder, such action or approval may be conditioned in any manner the Association deems appropriate or the Association may refuse to take or give such action or approval without the necessity of establishing the reasonableness of such conditions or refusal.

**12. Determination of the Common Expenses and Fixing of Assessments Therefor.** The Board of Directors shall from time to time, and at least annually, prepare a budget for the Condominium, determine the amount of Assessments payable by the Unit Owners to meet the Common Expenses of the Condominium, and allocate and assess such expenses among the Unit Owners in accordance with the provisions of this Declaration and the By-Laws. The Board of Directors shall advise all Unit Owners promptly, in writing, of the amount of the Assessment payable by each of them as determined by the Board of Directors as aforesaid and shall furnish copies of each budget, on which such Assessments are based, to all Unit Owners and (if requested in writing) to their respective mortgagees. The Common Expenses shall include the expenses of the operation, maintenance, repair and replacement of the Common Elements, Special Assessments levied against all of the Units of the Condominium, costs of carrying out the powers and duties of the Association and any other expenses designated as Common Expenses by the Act, this Declaration, the Articles or By-Laws of the Association, applicable rules and regulations, or by the Association. Any budget adopted shall be subject to change to cover actual expenses at any time. Any such change shall be adopted consistent with the provisions of the By-Laws. Additionally, any charges for cable television services and auxiliary services, if provided to all of the Units of the Condominium, shall be deemed to be a Common Expense. The Board of

OFF. REC. 1430276 456

Directors in determining the amount of the Assessments payable by the Unit Owners shall be authorized to include such charges in the estimated operating budget for the Condominium. Accordingly, the provisions contained in Section 13 of this Declaration with respect to the collection of Assessments shall be applicable to the charges for cable television services and auxiliary services.

13. Collection of Assessments and Special Assessments.

§13.1 Liability for Assessments and Special Assessments. A Unit Owner, regardless of how title is acquired, including a purchaser at a judicial sale, shall be liable for all Assessments and Special Assessments coming due while he is the Unit Owner. Except as provided for in Section 13.5, the grantee shall be jointly and severally liable with the grantor for all unpaid Assessments and Special Assessments against the grantor for his share of the Common Expenses up to the time of transfer of title, without prejudice to any right the grantee may have to recover from the grantor the amounts paid by the grantee. The liability for Assessments and Special Assessments may not be avoided by waiver of the use or enjoyment of any Common Elements or by the abandonment of the Unit for which the Assessments and Special Assessments are made or otherwise.

§13.2 Default in Payment of Assessments or Special Assessments for Common Expenses. Assessments, Special Assessments and installments thereof, not paid within ten (10) days from the date when they are due, shall bear interest at the highest rate allowable by law from the due date until paid. The Association has a lien on each Condominium Parcel for any unpaid Assessments and Special Assessments on such Parcel, with interest and for reasonable attorney's fees and costs incurred by the Association incident to the collection of the Assessments and Special Assessments or enforcement of the lien. The lien is effective from and after recording a claim of lien in the Public Records of the County, stating the description of the Condominium Parcel, the name of the record Owner, the amount due and the due dates. No such lien shall continue for a longer period than one year after the claim of lien has been recorded, unless within that time an action to enforce the lien is commenced in a court of competent jurisdiction. The claim of lien shall secure all unpaid Assessments and Special Assessments, interest, costs, and attorney's fees which are due and which may accrue subsequent to the recording of the claim of lien and prior to entry of a final judgment of foreclosure. A claim of lien shall be signed and acknowledged by an officer or agent of the Association. Upon payment the person making the payment is entitled to a satisfaction of the lien. The Association may bring an action in its name to foreclose a lien for unpaid Assessments and Special Assessments in the manner a mortgage of real property is foreclosed and may also bring an action at law to recover a money judgment for the unpaid Assessments and Special Assessments without waiving any claim of lien.

§13.3 Notice of Intention to Foreclose Lien. No foreclosure judgment may be entered until at least thirty (30) days after the Association gives written notice to the Unit Owner of its intention to foreclose its lien to collect the unpaid Assessments and Special Assessments. If this notice is not given at least thirty (30) days before the foreclosure action is filed, and if the unpaid Assessments and Special Assessments, including those coming due after the claim of lien is recorded, and other sums permitted hereunder are paid before the entry of a final judgment of foreclosure, the Association shall not recover attorney's fees or costs. The notice must be given by delivery of a copy of it to the Unit Owner or by certified or registered mail, return receipt requested, addressed to the Unit Owner at the last known address, and upon such mailing, the notice shall be deemed to have been given, and the court shall proceed with the foreclosure action and may award attorney's fees and costs as permitted

OFF: 1430278 457

by law. If after diligent search and inquiry the Association cannot find the Unit Owner or a mailing address at which the Unit the Owner will receive the notice, the court may proceed with the foreclosure action and may award attorney's fees and costs as permitted by law. The notice requirements of this subsection are satisfied if the Unit Owner records a Notice of Contest of Lien as provided in the Act and shall not apply if an action to foreclose a mortgage on the Unit is pending before any court, if the Association's rights would be affected by such foreclosure, and if actual, constructive or substitute service of process has been made on the Unit Owner.

- §13.4 Appointment of Receiver to Collect Rental. If the Unit Owner remains in possession of the Unit and the claim of lien is foreclosed, the court in its discretion may require the Unit Owner to pay a reasonable rental for the Unit and the Association is entitled to the appointment of a receiver to collect the rent.
- §13.5 Institutional First Mortgagee. In the event an Institutional First Mortgagee shall obtain title to the Condominium Parcel by a purchase at the public sale resulting from the Institutional First Mortgagee's foreclosure judgment in a foreclosure suit in which the Association has been properly named as a defendant junior lienholder, or as a result of a deed given in lieu of foreclosure, such Institutional First Mortgagee, its successors and assigns, shall not be liable for the share of Common Expenses or Assessments or Special Assessments or other charges imposed by the Association attributable to such Condominium Parcel or chargeable to the former Unit Owner of such Condominium Parcel which became due prior to acquisition of title as a result of the foreclosure or the acceptance of such deed in lieu thereof, unless such share is secured by a claim of lien that is recorded prior to the recording of the foreclosed mortgage. Such unpaid share of Common Expenses or Assessments or Special Assessments or other charges shall be deemed to be Common Expenses, collectable from all of the Unit Owners, including such acquirer, and such acquirer's successors and assigns.
- §13.6 Developer's Liability for Assessments. (a) The Developer shall be excused from the payment of the share of the Common Expenses and Assessments relating to Units it is offering for sale, for a period beginning with the recording of this Declaration and ending the first day of the fourth calendar month following the month in which the closing of the purchase and sale of the first Unit occurs. However, the Developer must pay the portion of Common Expenses incurred during that period which exceeds the amount assessed against other Unit Owners.
- (b) During the period from the first day of the fourth calendar month following the month in which the closing of the purchase and sale of the first Unit occurs, until the earlier of the date records of the Association is turned over to Unit Owners other than the Developer, or June 30, 1999 (the "Guarantee Expiration Date"), the Developer shall not be obligated to pay the share of the Common Expenses and Assessments attributable to Units it is offering for sale, provided that the regular monthly Assessments for Common Expenses imposed on each Unit Owner other than the Developer shall not increase during such period over the amount set opposite such Unit's Designation (model type) in the Estimated Operating Budget for the first twelve months of operation contained in the Offering Circular (Prospectus) delivered to such Unit Owner when such Owner contracted to purchase the Unit, if applicable; and provided further that the Developer shall be obligated to pay any amount of Common Expenses actually incurred during such period and not produced by the Assessments at the guaranteed level receivable from Unit Owners.

REC: 14302PG 458

(iii) No funds receivable from Unit purchasers or Owners payable to the Association or collected by the Developer on behalf of the Association, other than regular periodic Assessments for Common Expenses as provided in this Declaration and disclosed in the Estimated Operating Budget for the first twelve months of operation contained in the Offering Circular (Prospectus) delivered to such Unit purchaser or Owner when such Unit purchaser or Owner contracted to purchase the Unit, if applicable, shall be used for payment of Common Expenses prior to the Guarantee Expiration Date. This restriction shall apply to funds including, but not limited to, capital contributions or start-up funds collected from Unit purchasers at closing.

§13.7 Possession of Unit. Subject to the Association's rights under Section 7.5 of this Declaration and under law, any person who acquires an interest in a Unit, including Institutional First Mortgagees through foreclosure of a first mortgage of record (or deed in lieu thereof), including, without limitation, persons acquiring title by operation of law, shall be entitled to occupancy of the Unit and enjoyment of the Common Elements.

§13.8 Certificate of Unpaid Assessments. The Association shall provide a certificate stating all Assessments, Special Assessments and other moneys owed to the Association by the Unit Owner with respect to the Condominium Parcel, within 15 days after request by a Unit Owner or Institutional First Mortgagee.

§13.9 Installments. Assessments may be collected monthly or quarterly in advance, at the option of the Association, from time to time.

§13.10 Special Assessments. The specific purpose or purposes of any Special Assessment approved in accordance with this Declaration, Articles, or By-Laws shall be set forth in a written notice of such Special Assessment sent or delivered to each Unit Owner. The funds collected pursuant to a Special Assessment shall be used only for the specific purpose or purposes set forth in such notice, or returned to the Unit Owners. However, upon completion of such specific purpose or purposes, any excess funds shall be considered Common Surplus.

14. Insurance. Insurance covering portions of the Condominium Property shall be governed by the following provisions:

§14.1 Purchase, Custody and Payment.

- (a) Purchase. All insurance policies described herein covering portions of the Condominium Property shall be purchased by the Association and shall be issued by an insurance company authorized to do business in Florida.
- (b) Approval. Each insurance policy, the agency and company issuing the policy and the Insurance Trustee (if appointed) hereinafter described, shall be subject to the approval of the Primary Institutional First Mortgagee in the first instance.
- (c) Named Insured. The named insured shall be the Association, individually, and as agent for Owners of Units covered by the policy, without naming them and as agent for their mortgagees, without naming them. The Unit Owners and their mortgagees shall be additional insured.
- (d) Custody of Policies and Payment of Proceeds. All policies shall provide that payments for losses made by the insurer shall be paid to the Insurance Trustee (if

OFF: 14302PG 459  
REC:

appointed), and all policies and endorsements thereto shall be deposited with the Insurance Trustee (if appointed).

- (e) Copies to Mortgagees. One copy of each insurance policy, or a certificate evidencing such policy, and all endorsements thereto, shall be furnished by the Association upon request to each Institutional First Mortgagee who holds a mortgage upon a Unit covered by the policy. Copies or certificates shall be furnished not less than ten (10) days prior to the expiration of each preceding policy that is being renewed or replaced, as appropriate.
- (f) Personal Property and Liability. Unit Owners may obtain insurance coverage at their own expense and at their own discretion upon the property lying within the boundaries of their Unit, including, but not limited to, their personal property and for their personal liability and living expense and for any other risks.

§14.2 Coverage. The Association shall maintain insurance covering the following:

- (a) Casualty. The Building (including all fixtures, installations or additions comprising that part of the Building within the boundaries of the Units initially installed, or replacements thereof, of like kind or quality in accordance with the original plans and specifications therefor, or as existed at the time the Unit was initially conveyed if the original plans and specifications are not available, but excluding floor coverings, wall coverings and ceiling coverings, all furniture, furnishings or other personal property owned, supplied or installed by Unit Owners or tenants of Unit Owners) and all improvements located on the Common Elements from time to time, together with all service machinery contained therein (collectively, the "Insured Property"), shall be insured in an amount not less than 100% of the full insurable replacement value thereof, excluding foundation and excavation costs. Such policies may contain reasonable deductible provisions as determined by the Board of Directors of the Association. Such coverage shall afford protection against:
- i. Loss or damage by fire and other hazards covered by a standard extended coverage endorsement; and
  - ii. Such other risks as from time to time are customarily covered with respect to buildings and improvements similar to the Insured Property in construction, location and use, including, but not limited to, vandalism and malicious mischief.
- (b) Liability. Comprehensive general public liability and automobile liability insurance covering loss or damage resulting from accidents or occurrences on or about or in connection with the Insured Property or adjoining driveways and walkways, or any work, matters or things related to the Insured Property, with such coverage as shall be required by the Board of Directors of the Association, but with combined single limit liability of not less than \$200,000 for each accident or occurrence, \$100,000 per person and \$50,000 property damage, and with a cross liability endorsement to cover liabilities of the Unit Owners as a group to any Unit Owner, and vice versa.
- (c) Workers' Compensation and other mandatory insurance, when applicable.

OFF. REC. 14332PG 460

- (d) Flood Insurance, if required by the Primary Institutional First Mortgagee or if the Association so elects.
- (e) Fidelity Insurance, if required under the provisions of the Act, covering all directors, officers and employes of the Association and managing agents who handle Association funds, if any.
- (f) Such other insurance as the Board of Directors of the Association shall determine from time to time to be desirable.

When appropriate and obtainable, each of the foregoing policies shall waive the insurer's right to: (i) subrogation against the Association and against the Unit Owner's individually and as a group, (ii) the clause that reserves to the insurer the right to pay only a fraction of any loss in the event of co-insurer the right to pay only a fraction of any loss in the event of co-insurance or if other insurance carriers have issued coverage upon the same risk, and (iii) avoid liability for a loss that is caused by an act of the Board of Directors of the Association, or by a member of the Board of Directors of the Association or by one or more Unit Owners.

**§14.3 Additional Provisions.** All policies of physical damage insurance shall provide that such policies may not be cancelled or substantially modified without at least ten (10) days' prior written notice to all of the named insured, including all mortgagees of Units. Prior to obtaining any policy of casualty insurance or any renewal thereof, the Board of Directors shall obtain an appraisal from a fire insurance company or other competent appraiser, of the full insurable replacement value of the Insured Property (exclusive of foundations), without deduction for depreciation, for the purpose of determining the amount of insurance to be effected pursuant to this Section.

**§14.4 Premiums.** Premiums upon insurance policies purchased by the Association shall be paid by the Association as a Common Expense, except that the amount of increase in the premium occasioned by misuse, occupancy or abandonment of any one or more Units or their appurtenances or of the Common Elements by particular Unit Owners shall be assessed against and paid by such Owners. Premiums may be financed in such manner as the Board of Directors deems appropriate.

**§14.5 Insurance Trustee; Share of Proceeds.** All insurance policies obtained by the Association shall be for the benefit of the Association, the Unit Owners and their mortgagees, as their respective interests may appear, and shall provide that all proceeds covering property losses shall be paid to the Insurance Trustee which may be designated by the Board of Directors and which, if so appointed, shall be a bank or trust company in Florida with trust powers with its principal place of business in the County. The Insurance Trustee (if appointed) shall not be liable for payment of premiums, nor for the renewal or the sufficiency of policies nor for the failure to collect any insurance proceeds. The duty of the Insurance Trustee (if appointed) shall be to receive such proceeds as are paid and to hold the same in trust for the purposes elsewhere stated herein, and for the benefit of the Unit Owners and their respective mortgagees in the following shares, but which shares need not be set forth on the records of the Insurance Trustee:

- (a) **Insured Property.** Proceeds on account of damage to the Insured Property shall be held in undivided shares for each Unit Owner, such shares being the same as the undivided shares in the Common Elements appurtenant to each Unit, provided that if the Insured Property so damaged includes

OFF. REC: 1430213 461

property lying within the boundaries of specific Units, that portion of the proceeds allocable to such property shall be held as if that portion of the Insured Property were Optional Property as described in subparagraph (b) below.

- (b) Optional Property. Proceeds on account of damage solely to Units and/or certain options or all of the contents thereof not included in the Insured Property (all as determined by the Association in its sole discretion) (collectively, the "Optional Property"), if any is collected by reason of optional insurance which the Association elects to carry thereon (as contemplated herein), shall be held for the benefit of Owners of Units or other portions of the Optional Property damaged in proportion to the cost of repairing the damage suffered by each such affected Owner, which cost and allocation shall be determined in the sole discretion of the Association.
- (c) Mortgagees. No mortgagee shall have any right to determine or participate in the determination as to whether or not any damaged property shall be reconstructed or repaired, and no mortgagee shall have any right to apply or have applied to the reduction of a mortgage debt any insurance proceeds, except for actual distributions thereof made to the Unit Owner and mortgagee pursuant to the provisions of this Declaration.
- §14.6 Distribution of Proceeds. Proceeds of insurance policies received by the Insurance Trustee (if appointed) shall be distributed to or for the benefit of the beneficial Owners thereof in the following manner:
- (a) Expenses of the Trust. All expenses of the Insurance Trustee (if appointed) shall be first paid or provisions shall be made therefor.
- (b) Reconstruction or Repair. If the damaged property for which the proceeds are paid is to be repaired or reconstructed, the remaining proceeds shall be paid to defray the cost thereof as elsewhere provided herein. Any proceeds remaining after defraying such costs shall be distributed to the beneficial owners thereof, remittances to Unit Owners and their mortgagees being payable jointly to them.
- (c) Failure to Reconstruct or Repair. If it is determined in the manner elsewhere provided that the damaged property for which the proceeds are paid shall not be reconstructed or repaired, the remaining proceeds shall be allocated among the beneficial owners as provided in Section 14.5 above, and distributed first to all Institutional First Mortgagees in an amount sufficient to pay off their mortgages, and the balance, if any, to the beneficial owners.
- (d) Certificate. In making distribution to Unit Owners and their mortgagees, the Insurance Trustee (if appointed) may rely upon a certificate of the Association made by its President and Secretary as to the names of the Unit Owners and their mortgagees and their respective shares of the distribution.
- §14.7 Association as Agent. The Association is hereby irrevocably appointed as agent and attorney-in-fact for each Unit Owner and for each owner of a mortgage or other lien upon a Unit and for each owner of any other interest in the Condominium Property to adjust all claims arising under insurance policies purchased by the Association and to execute and deliver releases upon the payment of claims.

REF: 1430276 462

- §14.8 Unit Owners Personal Coverage. Insurance policies issued to individual Unit Owners shall provide that the coverage afforded by such policies is excess over the amount recoverable under any other policy covering the same property without rights of subrogation against the Association. Unless the Association elects otherwise, the insurance purchased by the Association shall not cover claims against an Owner due to accidents occurring within his Unit, nor casualty or theft loss to the contents of an Owner's Unit. It shall be the obligation of the individual Unit Owner, if such Owner so desires, to purchase and pay for insurance as to all such other risks not covered by insurance carried by the Association.
- §14.9 Benefit of Mortgagees. Certain provisions in this Section 14 entitled "Insurance" are for the benefit of mortgagees of Units and may be enforced by such mortgagees.
- §14.10 Insurance Trustee. The Board of Directors of the Association shall have the option in its discretion of appointing an Insurance Trustee hereunder. If the Association fails or elects not to appoint such Trustee, the Association will perform directly all obligations imposed upon such Trustee by this Declaration.
15. Reconstruction or Repair After Fire or Other Casualty.
- §15.1 Determination to Reconstruct or Repair. In the event of damage to or destruction of the Insured Property (and the Optional Property, if insurance has been obtained by the Association with respect thereto) as a result of fire or other casualty unless 75% or more of the Insured Property (and the Optional Property, if insurance has been obtained by the Association with respect thereto) is destroyed or substantially damaged and Unit Owners owning 80% or more of the applicable interests in the Common Elements elect to proceed with repairs or restoration and the Primary Institutional First Mortgagee approves such election, the Board of Directors shall arrange for the prompt repair and restoration of the Insured Property (and the Optional Property, if insurance has been obtained by the Association with respect thereto) and the Insurance Trustee, if appointed, shall disburse the proceeds of all insurance policies to the contractors engaged in such repair and restoration in appropriate progress payments. If 75% or more of the Insured Property (and the Optional Property, if insurance has been obtained by the Association with respect thereto) is substantially damaged or destroyed and if Unit Owners owning 80% of the applicable interests in the Common Elements duly and promptly resolve not to proceed with the repair or restoration thereof and the Primary Institutional First Mortgagee approves such resolution, the Condominium Property will not be repaired and shall be subject to an action for partition instituted by the Association, any Unit Owner, mortgagee or lienor, as if the Condominium Property were owned in common, in which event the net proceeds of insurance resulting from such damage or destruction shall be divided among all the Unit Owners in proportion to their respective interests in the Common Elements with respect to proceeds held for damage to the Insured Property other than that portion of the Insured Property lying within the boundaries of the Unit, and among affected Unit Owners in proportion to the damage suffered by each such affected Unit Owner, as determined in the sole discretion of the Association (with respect to proceeds held for damage to the Optional Property, if any, and to that portion of the Insured Property lying within the boundaries of the Unit); provided, however, that no payment shall be made to a Unit Owner until there has first been paid off out of his share of such fund all mortgages and liens on his Unit in the order or priority of such mortgages and liens. Whenever in this Section the words "promptly repair" are used, it shall mean that repairs are to begin not more than sixty (60) days from the date the Insurance Trustee (if appointed) notifies the Board of Directors and Unit Owners that it holds proceeds of insurance on account of such



OFF. REC. 14302PG 463

damage or destruction sufficient to pay the estimated cost of such work, nor not more than ninety (90) days after the Insurance Trustee (if appointed) notifies the Board of Directors and the Unit Owners that such proceeds of insurance are insufficient to pay the estimated costs of such work. The Insurance Trustee (if appointed) may rely upon a certificate of the Association made by its President and Secretary to determine whether or not the damaged property is to be reconstructed or repaired.

- §15.2 Plans and Specifications.** Any reconstruction or repair must be made substantially in accordance with the plans and specifications for the original improvements; or if not, then in accordance with the plans and specifications approved by the Board of Directors of the Association, and if the damaged property which is to be altered is the Building or the Optional Property, by the Owners of not less than 80% of the applicable interests in the Common Elements, as well as the Owners of all Units and other portions of the Optional Property (and their respective mortgagees) the plans for which are to be altered.
- §15.3 Special Responsibility.** If the damage is only to those parts of the Optional Property for which the responsibility of maintenance and repair is that of the respective Unit Owners, then the Unit Owners shall be responsible for all necessary reconstruction and repair (unless insurance proceeds are held by the Association with respect thereto by reason of the purchase of optional insurance thereon, in which case the Association shall have the responsibility to reconstruct and repair the damaged Optional Property, provided the respective Unit Owners shall be individually responsible for any amount by which the cost of such repair or reconstruction exceeds the insurance proceeds held for such repair or reconstruction on a Unit by Unit basis, as determined in the sole discretion of the Association). In all other instances, the responsibility for all necessary reconstruction and repair shall be that of the Association.
- §15.4 Estimate of Costs.** Immediately after a determination is made to rebuild or repair damage to property for which the Association has the responsibility of reconstruction and repair, the Association shall obtain reliable and detailed estimates of the cost to rebuild or repair.
- §15.5 Special Assessments.** If the proceeds of the insurance are not sufficient to defray the estimated costs of reconstruction and repair to be effected by the Association, or if at any time during reconstruction and repair or upon completion of reconstruction and repair the funds for the payment of the costs of reconstruction and repair are insufficient, Special Assessments shall be made against the Unit Owners in sufficient amounts to provide funds for the payment of such costs. Such Special Assessments on account of damage to the Insured Property shall be in proportion to all of the Owner's respective shares in the Common Elements, and on account of damage to the Optional Property, in proportion to the cost of repairing the damage suffered by each Owner thereof, as determined by the Association.
- §15.6 Construction Funds.** The funds for payment of the costs of reconstruction and repair, which shall consist of proceeds of insurance held by the Insurance Trustee (if appointed), and funds collected by the Association from Special Assessments against Unit Owners, shall be disbursed in payment of such costs in the following manner:
- (a) **Association.** If the total Special Assessments made by the Association in order to provide funds for payment of the costs of reconstruction and repair which are the responsibility of the Association are more than \$10,000, then the sums paid upon such Special Assessments shall be deposited by the Association with the Insurance Trustee (if

OFF.  
REC: 14302PG 464

appointed). In all other cases, the Association shall hold the sums paid upon such Special Assessments and disburse the same in payment of the costs of reconstruction and repair.

- (b) Disturment. The proceeds of insurance collected on account of a casualty, and the sums collected from Unit Owners on account of such casualty, shall constitute a construction fund which shall be disbursed in payment of the costs of reconstruction and repair in the following manner and order:

- (i) Association - Lesser Damage. If the amount of the estimated costs of reconstruction and repair which are the responsibility of the Association is less than \$50,000, then the construction fund shall be disbursed in payment of such costs upon the order of the Board of Directors of the Association; provided, however, that upon request to the Insurance Trustee (if appointed) by an Institutional First Mortgagee which is a beneficiary of an insurance policy, the proceeds of which are included in the construction fund, such fund shall be disbursed in the manner provided below for the reconstruction and repair of major damage.
- (ii) Association - Major Damage. If the amount of the estimated costs of reconstruction and repair which are the responsibility of the Association is more than \$50,000, then the construction fund shall be disbursed in payment of such costs in the manner contemplated by subparagraph (i) above, but then only upon the further approval of an architect qualified to practice in Florida and employed by the Association to supervise the work.
- (iii) Unit Owners. If there is a balance of insurance proceeds after payment of all costs of reconstruction and repair that are the responsibility of the Association, this balance may be used by the Association to effect repairs to the Special Property (if not insured or if under insured), or may be distributed to Owners of the Special Property who have the responsibility for reconstruction and repair thereof. The distribution shall be in the proportion that the estimated cost of reconstruction and repair of such damage to such affected Unit Owners bears to the total of such estimated costs to all affected Unit Owners, as determined by the Board; provided, however, that no Unit Owner shall be paid an amount in excess of the estimated costs of repair for his portion of the Special Property. All proceeds must be used to effect repairs to the Special Property, and if insufficient to complete such repairs, the Owners shall pay the deficit with respect to their portion of the Special Property and promptly effect the repairs. Any balance remaining after such repairs have been effected shall be distributed to the affected Unit Owners and their mortgagees jointly as elsewhere herein contemplated.
- (iv) Surplus. It shall be presumed that the first moneys disbursed in payment of cost of reconstruction and repair shall be from insurance proceeds. If there is a balance in a construction fund after payment of all costs relating to the reconstruction and repair for which the fund is established, such balance shall be distributed to the beneficial owners of the fund in the manner elsewhere stated, except, however, that part of a distribution to an Owner which is not in excess of Assessments paid by such Owner into the construction fund shall not be made payable to any mortgagee.

OFF: 1430270 465

- (v) Certificate. Notwithstanding the provisions herein, the Insurance Trustee (if appointed) shall not be required to determine whether or not sums paid by Unit Owners upon Special Assessments shall be deposited by the Association with the Insurance Trustee (if appointed), nor to determine whether the disbursements from the construction fund are to be made upon the order of the Association alone or upon the additional approval of an architect or otherwise, nor whether a disbursement is to be made from the construction fund, nor to determine whether surplus funds to be distributed are less than the Special Assessments paid by Owners, nor to determine the payees nor the amounts to be paid. The Insurance Trustee (if appointed) may rely upon a certificate of the Association, made by its President and Secretary, as to any or all of such matters and stating that the sums to be paid are due and properly payable, and stating the names of the payees and the amounts to be paid.

§15.7 Benefit of Mortgagees. Certain provisions in this Section 15 are for the benefit of mortgagees of Units and may be enforced by any of them.

16. Condemnation.

§16.1 Deposit of Awards with Insurance Trustee. The taking of portions of the Condominium Property by the exercise of the power of eminent domain shall be deemed to be a casualty, and the awards for that taking shall be deemed to be proceeds from insurance on account of the casualty and shall be deposited with the Insurance Trustee (if appointed). Even though the awards may be payable to Unit Owners, the Unit Owners shall deposit the awards with the Insurance Trustee (if appointed); and in the event of failure to do so, in the discretion of the Board of Directors of the Association, a Special Assessment shall be made against a delinquent Unit Owner in the amount of his award, or the amount of that award shall be set off against the sums hereafter made payable to that Owner.

§16.2 Determination Whether to Continue Condominium. Whether the Condominium will be continued after condemnation will be determined in the manner provided for determining whether damaged property will be reconstructed and repaired after casualty. For this purpose, the taking by eminent domain shall also be deemed to be a casualty.

§16.3 Disbursement of Funds. If the Condominium is terminated after condemnation, the proceeds of the awards and Special Assessments will be deemed to be insurance proceeds and shall be owed and distributed in the manner provided with respect to the ownership and distribution of insurance proceeds if the Condominium is terminated after a casualty. If the Condominium is not terminated after condemnation, the size of the Condominium will be reduced and the property damaged by the taking will be made usable in the manner provided below. The proceeds of the awards and Special Assessments shall be used for these purposes and shall be disbursed in the manner provided for disbursement of funds by the Insurance Trustee (if appointed) after a casualty, or as elsewhere in this Section is specifically provided.

§16.4 Unit Reduced but Habitable. If the taking reduces the size of a Unit and the remaining portion of the Unit can be made habitable (in the sole opinion of the Association), the award for the taking of a portion of the Unit shall be used for the following purposes in the order stated and the following changes shall be made to the Condominium:

OFF: 1430270 466  
REC: 1430270 466

- (a) Restoration of Unit. The Unit shall be made habitable. If the cost of the restoration exceeds the amount of the award, the additional funds required shall be assessed against the Owner of the Unit.
- (b) Distribution of Surplus. The balance of the award in respect of the Unit, if any, shall be distributed to the Owner of the Unit and to each mortgagee of the Unit, the remittance being made payable jointly to the Owner and such mortgagees.
- (c) Adjustment of Shares in Common Elements. If the floor area of the Unit is reduced by the taking, the percentage representing the share in the Common Elements and of the Common Expenses and Common Surplus appurtenant to the Unit shall be reduced by multiplying the percentage of the applicable Unit prior to reduction by a fraction, the numerator of which shall be the area in square feet of the Unit after the taking and the denominator of which shall be the area in square feet of the Unit before the taking. The shares of all Unit Owners in the Common Elements, Common Expenses and Common Surplus shall then be restated as follows:
- (i) add the total of all percentages of all Units after reduction as aforesaid (the "Remaining Percentage Balance"); and
  - (ii) divide each Percentage for each Unit after reduction as aforesaid by the Remaining Percentage Balance.

The result of such division for each Unit shall be the adjusted percentage for such Unit.

§10.5 Unit Made Uninhabitable. If the taking is of the entire Unit or so reduces the size of a Unit that it cannot be made habitable (in the sole opinion of the Association), the award for the taking of the Unit shall be used for the following purposes in the order stated and the following changes shall be made to the Condominium:

- a. Payment of Award. The awards shall be paid first to the applicable Institutional First Mortgage in amounts sufficient to pay off their mortgages in connection with each Unit which is not so habitable; second, to the Association for any due and unpaid Assessments and Special Assessments; third, jointly to the affected Unit Owners and other mortgagees of their Units. In no event shall the total of such distributions in respect of a specific Unit exceed the market value of such Unit immediately prior to the taking. The balance, if any, shall be applied to repairing and replacing the Common Elements.
- b. Addition to Common Elements. The remaining portion of the Unit, if any, shall become part of the Common Elements and shall be placed in a provision allowing, to the extent possible, for use by all of the Unit Owners in the manner approved by the Board of Directors of the Association; provided that if the cost of the work therefor shall exceed the balance of the fund from the award for the taking, such work shall be approved in the manner elsewhere required for capital improvements to the Common Elements.
- c. Adjustment of Shares. The shares in the Common Elements, Common Expenses and Common Surplus appurtenant to the Units that continue as part of the Condominium shall be adjusted to distribute the shares in the Common Elements, Common Expenses and Common Surplus among the reduced number of Unit Owners (and among reduced Units). This shall be effected by restating the shares of continuing Unit Owners as follows:

REF: 14302PC 467

- (i) add the total of all percentages of all Units of continuing Owners prior to this adjustment, but after any adjustments made necessary by Section 16.4(c) hereof (the "Percentage Balance"); and
- (ii) divide the percentage of each Unit of a continuing Owner prior to this adjustment, but after any adjustments made necessary by Section 16.4(c) hereof, by the Percentage Balance.

The result of such division for each Unit shall be the adjusted percentage for such Unit.

- (d) Special Assessments. If the balance of the award (after payments to the Unit Owner and such Owner's mortgagees as above provided) for the taking is not sufficient to alter the remaining portion of the Unit for use as a part of the Common Elements, the additional funds required for such purposes shall be raised by Special Assessments against all of the Unit Owners who will continue as Owners of Units after the changes in the Condominium affected by the taking. The Special Assessments shall be made in proportion to the applicable percentage shares of those Owners after all adjustments to such shares affected pursuant hereto by reason of the taking.
- (e) Arbitration. If the market value of a Unit prior to the taking cannot be determined by agreement between the Unit Owner and mortgagees of the Unit and the Association within thirty (30) days after notice of a dispute by any affected party, such value shall be determined by arbitration in accordance with the then existing rules of the American Arbitration Association, except that the arbitrators shall be two appraisers appointed by the American Arbitration Association who shall base their determination upon an average of their appraisals of the Unit. A judgment upon the decision rendered by the arbitrators may be entered in any court of competent jurisdiction in accordance with the Florida Arbitration Code. The cost of arbitration proceedings shall be assessed against all Unit Owners, including Owners who will not continue after the taking, in proportion to the applicable percentage shares of such Owners as they exist prior to the adjustments to such shares affected pursuant hereto by reason of the taking.

§16.6 Taking of Common Elements. Awards for the taking of Common Elements shall be used to render the remaining portion of the Common Elements usable in the manner approved by the Board of Directors of the Association; provided that if the cost of such work shall exceed the balance of the funds from the awards for the taking, the work shall be approved in the manner elsewhere required for capital improvements to the Common Elements. The balance of the awards for the taking of Common Elements, if any, shall be distributed to the Unit Owners in the shares in which they own the Common Elements after adjustments to these shares effected pursuant hereto by reason of the taking. If there is a mortgage on a Unit, the distribution shall be paid jointly to the Owner and the mortgagees of the Unit.

§16.7 Discretion of Board. In circumstances not covered by this Declaration or by law, a two-thirds (2/3) majority of the Board may, upon an opinion of counsel that its decision is reasonable, deal with the condemnation in such reasonable manner as it determines to be appropriate under the circumstances.

§16.8 Amendment of Declaration. The changes in Units, in the Common Elements and in the ownership of the Common Elements and share in the Common Expenses and Common Surplus that are affected by the taking shall be evidenced by an amendment to this Declaration that

REC-14302PG 468

is only required to be approved by and executed upon the direction of a majority of all Directors of the Association.

17. Occupancy and Use Restrictions. In order to provide for congenial occupancy of the Condominium Property and for the protection of the values of the Units, the use of the Condominium Property shall be restricted to and shall be in accordance with the following provisions:

§17.1 Occupancy. Each Unit shall be used as a residence only, except as otherwise herein expressly provided. A Unit owned by an individual, corporation, partnership, trust or other fiduciary may only be occupied by the following persons, and such persons' families and guests: (i) the individual Unit Owner, (ii) an officer, director, stockholder or employee of such corporation, (iii) a partner or employee of such partnership, (iv) the fiduciary or beneficiary of such fiduciary, or (v) permitted occupants under an approved lease or sublease of the Unit (as described below), as the case may be.

Occupants of an approved lease or subleased Unit must be the following persons, and such persons' families and guests: (i) an individual lessee or sublessee, (ii) an officer, director, stockholder or employee of a corporate lessee or sublessee, or (iv) a fiduciary or beneficiary of a fiduciary lessee or sublessee.

Under no circumstances may more than one family reside in a Unit at one time. "Families" or words of similar import used herein shall be deemed to include spouses, parents, parents-in-law, brothers, sisters, children and grandchildren. In no event shall occupancy (except for temporary occupancy by visiting guests) exceed two (2) persons per bedroom. The Board of Directors shall have the power to authorize occupancy of a Unit by persons in addition to those set forth above. The provisions of this Section 17.1 shall not be applicable to Units used by the Developer for model apartments, sales offices, other offices or management services.

§17.2 Children. Children will be the direct responsibility of their parents or legal guardians, including full supervision of them while within the Condominium Property and including full compliance by them of these restrictions and all rules and regulations of the Association.

§17.3 Pets. Pets shall be kept within a Unit and not be permitted on any portion of the Condominium Property except when adequately secured and restrained by a leash, where applicable, and all such pets shall be walked in such areas designated by the Association so as to control the deposit of animal waste on the Condominium Property. No guests or invitees of an Owner shall be permitted to bring animals of any kind on the Condominium Property. No animals shall be allowed to commit a nuisance on any public portion of the Condominium Property. The term "pet" shall be limited to a dog, cat, or small domestic bird. Toys may not be kept in limited Common Elements when the Owner is not in the Unit.

Each Unit Owner owning a pet shall assume full responsibility for personal injuries or property damage caused by his pet, and each Unit Owner hereby agrees to indemnify the Association and all other Unit Owners and hold them harmless against any loss, claim or liability of any kind whatsoever arising from or growing out of any harm, injury, or damage caused by such Unit Owner's pet. Without limiting the generality of Section 17 hereof, violation of the provisions of this paragraph shall entitle the Association to all of its rights and remedies, including, but not limited to, the right to fine Unit Owners (as provided in any applicable rules and regulations), and/or to require any pet to be permanently removed from the Condominium Property upon three (3) days' notice.

REC: 1430270 469

- §17.4 Alterations. Without limiting the generality of Section 9.1 hereof, no Unit Owner shall cause or allow improvements or changes to any Unit, Limited Common Elements appurtenant thereto or Common Elements, including but not limited to, painting or other decorating of any nature, installing any electrical wiring, television antennae, machinery or air-conditioning units or in any manner changing the appearance of any portion of the Building, without obtaining the prior written consent of the Association (in the manner specified in Section 9.1 hereof).
- §17.5 Use of Common Elements. The Common Elements shall be used only for furnishing of the services and facilities for which they are reasonably suited and which are incident to the use and occupancy of Units.
- §17.6 Nuisances. No nuisances (as defined by the Association) shall be allowed on the Condominium Property, nor shall any use or practice be allowed which is a source of annoyance to residents or occupants of Units or which interferes with the peaceful possession or proper use of the Condominium Property by its residents or occupants.
- §17.7 No Improper Uses. No improper, offensive, hazardous or unlawful use shall be made of the Condominium Property or any part thereof, and all valid laws, zoning ordinances and regulations of all governmental bodies having jurisdiction thereover relating to any portion of the Condominium Property, shall be corrected by and at the sole expense of the party obligated to maintain or repair such portion of the Condominium Property, as elsewhere herein set forth.
- §17.8 Leases. No portion of a Unit (other than an entire Unit) may be rented. All leases shall be on forms approved by the Association and shall provide that the Association shall have the right to terminate the lease upon default by the tenant in observing any of the provisions of this Declaration, the Articles and By-Laws of the Association, applicable rules and regulations or other applicable provisions or any agreement, document or instrument governing the Condominium or administered by the Association. Leasing of Units shall also be subject to the prior written approval of the Association and the Association may reject the leasing of any Unit on any grounds the Association elects. No lease shall be approved for a term of less than six (6) months. Unit Owners wishing to lease their Units shall be required to place in escrow with the Association a sum to be determined by the Association which may be used by the Association to repair any damage to the Common Elements resulting from acts or omissions of tenants as determined in the sole discretion of the Association. The Unit Owner will be jointly and severally liable with the tenant to the Association for any amount in excess of such sum which is required by the Association to effect such repairs or to pay any claim for injury or damage to property caused by the negligence of the tenant. Any balance remaining in the escrow account, less an administrative charge determined by the Association, shall be returned to the Unit Owner within ninety (90) days after the tenant and all subsequent tenants permanently move out. All leases shall also comply with and be subject to the provisions of Section 15 hereof.
- §17.9 Exterior Improvements; Landscaping. Without limiting the generality of Section 9.1 or Section 17.4 hereof, no Unit Owner shall cause anything to be affixed or attached to, hung, displayed or placed on the exterior walls, doors, balconies or windows of the Building (including, but not limited to, awnings, signs, storm shutters, screens, furniture, fixtures and equipment), nor to plant or grow any type of shrubbery, flower, tree, vine, grass or other plant life outside his Unit, without the prior written consent of the Association.

OFF: 14302PG 470

- §17.10 Effect on Developer; Association. The restrictions and limitations set forth in this Section 17 shall not apply to the Developer or to Units owned by the Developer unless the Rules of the Florida Department of Business Regulation or the Act require otherwise. The Association shall have the power (but not the obligation) to grant relief in particular circumstances from the provisions of specific restrictions contained in this Section 17 for good cause shown.
18. Selling, Leasing and Mortgaging of Units. No Unit Owner other than the Developer may sell or lease his Unit except by complying with the following provisions:
- 18.1 Right of First Refusal. Any Unit Owner who receives a bona fide offer to purchase or lease his Unit (such offer to purchase or lease a Unit, as the case may be, is called an "Outside Offer" the party making any such Outside Offer is called an "Outside Offeror" and the Unit Owner to whom the Outside Offer is made is called an "Offeree Unit Owner"), which he intends to accept shall give notice by registered mail to the Board of Directors of the receipt of such Outside Offer. Said Notice shall also state the name and address of the Outside Offeror, the terms of the proposed transaction and such other information as the Board of Directors may reasonably require. The giving of such notice to the Board of Directors shall constitute an offer by such Unit Owner to sell his Unit or to lease his Unit to the Association or its designee upon the same terms and conditions as contained in such Outside Offer and shall also constitute a Warranty and representation by the Unit Owner who has received such Outside Offer to the Association that such Unit Owner believes the Outside Offer to be bona fide in all respects. The Offeree Unit Owner shall submit in writing such further information with respect thereto as the Board of Directors may reasonably request. Not later than twenty (20) days after receipt of such notice, together with such further information as may have been requested, the Association or its designee may elect, by sending written notice to such Offeree Unit Owner before the expiration of said twenty (20) day period, by certified mail, to purchase such Unit or to lease such Unit as the case may be, upon the same terms and conditions as contained in the Outside Offer and as stated in the notice from the Offeree Unit Owner. In the event the Association shall timely elect to purchase such Unit or to lease such Unit, or to cause the same to be purchased or leased by its designee, title shall close or a lease shall be executed at the office of the attorneys for the Association, in accordance with the terms of the Outside Offer, within forty-five (45) days after the giving of notice by the Association of its election to accept such offer. If, pursuant to such Outside Offeror was to assume or take title to the Unit subject to the Offeree Unit Owner's existing mortgage or mortgages, the Association may purchase the Unit and assume or take title to the Unit subject to said existing mortgage or mortgages, as the case may be. At the closing, the Offeree Unit Owner, if such Unit is to be sold, shall convey the same to the Association, or to its designee, by statutory warranty deed, with all tax and or documentary stamps adjoined at the expense of such Unit Owner, who shall also pay all other taxes arising out of such sale. Title shall be good and marketable and insurable and the Offeree Unit Owner shall deliver an abstract or provide a title binder (and subsequently, title insurance) at his expense at least thirty (30) days prior to such closing. Real estate taxes, mortgage interest, if any, and Common Expenses shall be apportioned between the Offeree Unit and the Association, or its designee, as of the closing date. In the event such Unit is to be leased, the Offeree Unit Owner shall execute and deliver to the Board of Directors or to its designee, a lease between the Offeree Unit Owner, as Landlord, and the Association, or its designee, as tenant, covering such Unit, for the rental and term contained in such Outside Offer.



REC: 14302PG 471

In the event the Association or its designee shall fail to accept such offer or, in the case of a lease, shall fail to reject the proposed lease as permitted by Section 17.8 hereof, within twenty (20) days after receipt of notice and all additional information requested, as aforesaid the Offeror Unit Owner shall be free to accept the Outside Offer within sixty (60) days after (i) notice of refusal is given by the Association, or (ii) the expiration of the period in which the Association or its designee might have accepted such offer, as the case may be. In the event the Offeree Unit Owner shall not, within such sixty (60) day period, accept, in writing, the Outside Offer or if the Offeree Unit Owner shall accept the Outside Offer within such sixty (60) day period but such sale or lease, as the case may be, shall not be consummated in accordance with the terms of such Outside Offer or within a reasonable time after the date set for closing thereunder, then, should such Offeree Unit Owner thereafter elect to sell such Unit or to lease such Unit, as the case may be, the Offeror Unit Owner shall be required to again comply with all of the terms and provisions of this Section.

Any deed or lease to an Outside Offeror shall provide (or shall be deemed to provide) that the acceptance thereof by the grantee or tenant shall constitute an assumption of the provisions of the Declaration, the By-Laws, the Articles of Incorporation, applicable rules and regulations and all other agreements, documents or instruments affecting the Condominium Property or administered by the Association, as the same may be amended from time to time.

Any lease executed in connection with the acceptance of any Outside Offer to lease a Unit shall be consistent herewith and with the By-Laws and rules and regulations and shall provide specifically that (i) it may not be modified, amended, extended or assigned without the prior consent in writing of the Board of Directors, (ii) the tenant shall not assign his interest in such lease or sublet the demised premises or any part thereof without the prior consent in writing of the Board of Directors, and (iii) the Board of Directors shall have the power, but shall not be obligated, to terminate such lease and to bring summary proceedings to evict the tenant in the name of the landlord thereunder, in the event of (A) a default by the tenant in the performance of its obligations to comply with the documents described in the preceding unnumbered paragraph under such lease, or (B) a foreclosure of the lien granted under the Act. Such lease shall also comply with the provisions of Section 17.8 hereof.

Except as hereinafter set forth, the form of any such lease executed by the Association or an Outside Offeror shall contain such other modifications as shall be approved in writing by the Board of Directors. Any lease executed by the Association as tenant shall provide that the Association may enter into a sublease of the premises without the consent of the landlord.

Any purported sale or lease of a Unit in violation of this Section shall be voidable at any time at the election of the Association and if the Board of Directors shall be so elected, the Unit Owner shall be deemed to have authorized and empowered the Association to institute legal proceedings to evict the purported tenant (in case of an unauthorised leasing, in the name of said Unit Owner as the purported landlord. Said Unit Owner shall reimburse the Association for all expenses (including attorney's fees and disbursements) incurred in connection with such proceedings.

The foregoing restrictions shall not apply to Units owned by or leased to the Developer or by or to any Institutional First Mortgagee acquiring title by foreclosure or by a deed in lieu of foreclosure. The Developer and such Institutional First Mortgagees shall have the right to sell, lease or sublease Units they own or lease without having to first offer the same for sale or lease to the Association.

REF: 14302PG 472

- §18.2 Consent of Unit Owners to Purchase or lease of Units by the Association.** The Association shall not exercise any option hereinabove set forth to purchase or lease any Unit without the prior approval of Owners of a majority of the voting interests present in person or by proxy and voting at a meeting at which a quorum has been obtained.
- §18.3 No Severance of Ownership.** Except as elsewhere herein provided, no part of the Common Elements may be sold, conveyed or otherwise disposed of, except as an appurtenance to the Unit in connection with a sale, conveyance or other disposition of the Unit to which such interest is appurtenant, and any sale, conveyance or other disposition of a Unit shall be deemed to include that Unit's appurtenant interest in the Common Elements.
- §18.4 Release by the Association of the Right of First Refusal.** The right of first refusal contained in Section 18.1 may be released or waived by the Association only in the manner provided in Section 18.5. In the event the Association shall release or waive its right of first refusal as to any Unit, such Unit may be sold, conveyed or leased free and clear of the provisions of said Section 18.1.
- §18.5 Certificate of Termination of Right of First Refusal.** A certificate executed and acknowledged by an officer of the Association stating that the provisions of Section 18.1 have been satisfied by a Unit Owner, or stating that the right of first refusal contained therein has been duly released or waived by the Association and that, as a result thereof, the rights of the Association thereunder have terminated. The certificate shall be conclusive with respect to all persons who rely on such certificate in good faith. The Board of Directors shall furnish such certificate upon request to any Unit Owner in respect to whom the provisions of such Section have, in fact, terminated or been waived.
- §18.6 Financing of Purchase of Units by the Association.** The purchase of any Unit by the Association shall be made on behalf of all Unit Owners. If the available funds of the Association are insufficient to effectuate any such purchase, the Board of Directors may levy a Special Assessment against each Unit Owner (other than the offeree Unit Owner), in proportion to his share of the Common Expenses, and/or the Board of Directors may, in its discretion, finance the acquisition of such Unit; provided, however, that no such financing may be secured by an encumbrance or hypothecation of any portion of the Condominium Property other than the Unit to be purchased.
- §18.7 Exceptions.** The provisions of Section 18.1 shall not apply with respect to any lease, sale or conveyance of any Unit by (a) the Unit Owner thereof to his spouse, children, parents, parents-in-law, siblings or a trustee, corporation or other entity where the Unit Owner or the aforementioned related persons are and continue to be the sole beneficiary or equity owner of such trustee, corporation or other entity, or to any one or more of the above, (b) the Developer, (c) the Association, (d) any proper officer conducting the sale of a Unit in connection with the foreclosure of a mortgage or other loan covering such Unit or delivering a deed in lieu of foreclosure, or (e) an Institutional First Mortgagee (or its designee) deriving title by virtue of foreclosure of its mortgage or acceptance of a deed in lieu of foreclosure; provided, however, that each succeeding Unit Owner shall be bound by, and his Unit subject to, the provisions of this Section 18.
- §18.8 Gifts and Bequests, etc.** Any Unit Owner shall be free to convey or transfer his Unit by gift, to devise his Unit by will, or to have his Unit pass by intestacy, without restrictions; provided, however, that each succeeding Unit Owner shall be bound by and his Unit subject to, the provisions of this Section 18.

REC-143C2PG 473

- §18.9 Mortgage of Units. Each Unit Owner shall have the right to mortgage his Unit without restriction.
- §18.10 Transfer Fees. The Association may, at its option, charge a transfer fee in connection with the furnishing of a certificate in accordance with Section 18.5 for the sale, lease or sublease of a Unit in connection with the Association's right of first refusal provided for in this Section 18; provided, however, if the lease or sublease is a renewal (or if a lease or sublease is with the same lessee or sublessee, no charge shall be made. The transfer fee may be preset by the Association but in no event shall it exceed the maximum amount allowed under the Act.
19. Compliance and Default. Each Unit Owner and every occupant of a Unit and the Association shall be governed by and shall comply with the terms of this Declaration and all exhibits annexed hereto, and the rules and regulations adopted pursuant to those documents, as the same may be amended from time to time. The Association (and Unit Owners, if appropriate) shall be entitled to the following relief in addition to the remedies provided by the Act:
- §19.1 Negligence. A Unit Owner shall be liable for the expense of any maintenance, repair or replacement made necessary by his negligence or by that of any member of his family or his or their guests, employees, agents or lessees, but only to the extent such expense is not met by the proceeds of insurance actually collected in respect of such negligence by the Association.
- §19.2 Compliance. In the event a Unit Owner or occupant fails to maintain a Unit or fails to cause such Unit to be maintained, or fails to observe and perform all of the provisions of this Declaration, the By-Laws, the Articles of the Association, applicable rules and regulations or any other agreement, document or instrument affecting the Condominium Property or administered by the Association, in the manner required, the Association shall have the right to proceed in a court of equity to require performance and or compliance, to impose any applicable fines and to sue in a court of law for damages. In addition, the Association has the irrevocable right of access to each Unit during reasonable hours when necessary for the maintenance, repair, or replacement of any Common Elements or for making emergency repairs which are necessary to prevent damage to the Common Elements or to another Unit or Units.
- §19.3 Costs and Attorneys' Fees. In any proceeding arising because of an alleged failure of a Unit Owner or the Association to comply with the requirements of the Act, this Declaration, the exhibits annexed hereto or the rules and regulations adopted pursuant to said documents, as the same may be amended from time to time, the prevailing party shall be entitled to recover the costs of the proceeding and such reasonable attorneys' fees (including appellate attorneys' fees) as may be awarded by the court.
- §19.4 No Waiver of Rights. The failure of the Association or any Unit Owner to enforce any covenant, restriction or other provisions of the Act, this Declaration and the exhibits annexed hereto, or the rules and regulations adopted pursuant to said documents, as the same may be amended from time to time, shall not constitute a waiver of their right to do so thereafter.
20. Merger of Condominium. The Condominium may be merged with one or more condominiums within the Development to form a single condominium upon (i) the approval of such voting interests of each condominium as is required by the Declaration for modifying the appurtenances to the Units or changing the proportion or percentages by which the Owners of the Condominium parcel share the Common Expenses and own the Common Surplus, (ii) the approval of all of the Institutional First Mortgages and of all record owners of Liens and (iii) upon the recording of new

REC: 14302PG 474

or amended Articles of Incorporation, Declaration(s) of Condominium and By-Laws.

21. Termination of Condominium. The Condominium shall continue until (i) terminated by casualty loss, condemnation or eminent domain, as more particularly provided in this Declaration, or (ii) such time as withdrawal of the Condominium Property from the provisions of the Act is authorized by a vote of Owners owning at least seventy-five (75%) percent of the applicable interest in the Common Elements (after twenty (20%) percent of the Units have been sold to Unit Owners other than the Developer, the Developer will not vote the Units owned by it for such withdrawal unless the Owners of at least seventy-five (75%) percent of all other applicable interests in the Common Elements so elect for such withdrawal, at which time Developer may choose to vote either in favor of or against withdrawal from Condominium ownership, as it sees fit), and by the Primary Institutional First Mortgagee. In the event such withdrawal is authorized as aforesaid, the Condominium Property shall be subject to an action for partition by any Unit Owner, mortgagee or lienor as if owned in common in which event the net proceeds of sale shall be divided among all Unit Owners in proportion to their respective interest in the Common Elements, provided, however, that no payment shall be made to a Unit Owner until there has first been paid off out of his share of such net proceeds all mortgages and liens of his Unit in the order of their priority. The termination of the Condominium, as aforesaid, shall be evidenced by a certificate of the Association executed by its President and Secretary, certifying as to the basis of the termination and said certificate shall be recorded among the Public Records of the County. This section may not be amended without the consent of all Institutional First Mortgagees and the Developer so long as it owns any Unit.
22. Additional Rights of Institutional First Mortgagees. In addition to all other rights herein set forth, Institutional First Mortgagees shall have the right, upon written request to the Association, to:
- §22.1 Examine the Association's books and records; and require copies of the annual reports and other financial data;
  - §22.2 Receive notice of Association meetings and attend such meetings;
  - §22.3 Receive notice of an alleged default by any Unit Owner, for whom such Institutional First Mortgagee holds a mortgage, which is not cured within thirty (30) days of notice of default to such Unit Owner; and
  - §22.4 Receive notice of any substantial damage or loss to any portion of the Condominium Property.
23. Execution of Documents Required by Dade County, Florida. The Developer's plan for the development of the Costa del Sol Project as a community may require from time to time the execution of certain documents required by Dade County, Florida. To the extent that said documents require the joinder of any or all property owners in the Costa del Sol Project - Stage 1, each of said Owners, by virtue of his acceptance of a deed to his Unit, does irrevocably give and grant to the Developer, or any of its officers individually, full power of attorney to execute said documents as his agent and in his place and stead.
24. The Costa del Sol Project.
- a) Background Information. The original developer of the Costa del Sol Project was the Costa del Sol Golf & Racquet Club, Inc., a Florida corporation, (the "Original Developer"). The Costa del Sol Project was established under the terms and provisions of the Act by the Original Developer as a "Phase Development".
- The Original Developer created four condominiums consisting of 371 residential condominium units and known as Costa del Sol

OFF. REC. 1430216 475

Condominium No. 1 (66 Units), Costa del Sol Condominium No. 2 (36 Units) Costa del Sol Condominium No. 3 (53 Units) and Costa del Sol Condominium No. 4 (46 Units). The Original Developer caused to be formed the Costa del Sol Association, Inc., a corporation not for profit (the "Original Association"). The Original Association is responsible for maintenance, operation, administration and upkeep of each of the condominiums as well as the Common Areas. The structure of the Original Association is "open-ended" and contemplates the admission of additional unit owners as members if, as and when, additional Condominiums are established at the Costa del Sol Project, (i.e., the Unit Owners in this Condominium).

The Original Developer caused to be prepared and placed of record on July 2, 1974, in Official Records Book 8718 at Page 847 of the Public Records of Dade County, Florida, an instrument entitled Declaration of Restrictions and Maintenance Covenants for "Costa del Sol" and Exhibits thereto (the "Original Declaration"), which instrument provides for, among other things, the rights, benefits, duties, obligations and burdens imposed upon the owners of property in the Costa del Sol Project (for example, the future owners of condominium units including the condominium units in this Condominium) with respect to the Common Areas.

The covenants, restrictions, easements, conditions, liens and assessments set forth in the Original Declaration and all amendments thereto, are covenants running with the title to the respective Units and are binding upon the Owners thereof, their heirs, successors and assigns, as provided in said instruments. However, this Declaration shall not have the effect of reimposing the covenants, restrictions, easements, conditions, liens and assessments contained in the Original Declaration and all amendments thereto upon the Units or the Owners thereof.

- (b) The Common Areas - Rights and Obligations of Unit Owners and Association No. 1 (Original Association). The Original Developer and the members of the Original Association have an unrestricted and perpetual easement of ingress and egress to, over, under, above and upon the Common Areas, as Common Areas are defined in the Original Declaration. These easements and the easement of enjoyment to the Common Areas in favor of every present and future owner of any "lot" in the Costa del Sol Project are subject to the rights of either the Original Developer or Original Association to do certain acts and things in respect of the aforesaid Common Areas, as provided for in the Original Declaration.

Additionally, the Original Declaration imposes certain obligations on owners of condominium units in the existing condominiums in Costa del Sol Project - Stage 1, on the Unit Owners in this Condominium and future unit owners.

Pursuant to the provisions of that certain Declaration of Covenants, Restrictions and Easements for Common Areas recorded on May 8, 1974 under Clerk's File No. 82422155 (and as may be amended by recorded Supplemental Declarations) in the Public Records of Dade County, Florida every Unit Owner shall have a non-exclusive perpetual easement of ingress and egress to, over, under, above and upon the Common Areas, as Common Areas are defined in the Common Areas Declaration, which easement shall be appurtenant to and shall pass with title to every Unit. The covenants, restrictions, easements, conditions, equitable servitudes, liens and assessments set forth in said Common Areas Declaration (including recorded Supplemental Declarations), shall be covenants running with the title to the respective Units and shall be binding upon the Owners thereof, their heirs, successors and assigns, as provided in said instrument. Until a court makes a final determination in respect of the obligation of Association No. 1 to maintain and cure the Common Areas, the Developer has a future

OFF: 1430216 476

owner of the Common Areas) would be reluctant to convey or cause the Successor Developer to convey title to the Common Areas to Association No. 1. The Developer (so long as Developer is in control of Association No. 2) through its designees as members of the Board of Directors of Association No. 2 intends to assess the members of Association No. 2 (the Unit Owners in this Condominium and existing and future unit owners in the Costa del Sol Project - Stage 2) for the maintenance obligation of the Common Areas.

25. Covenant Running With The Land. All provisions of this Declaration, the Articles, By-Laws and applicable rules and regulations of the Association shall, to the extent applicable and unless otherwise expressly herein or therein provided to the contrary, be perpetual and be construed to be covenants running with the Land and with every part thereof and interest therein, and all of the provisions hereof and thereof shall be binding upon and inure to the benefit of the Developer and subsequent owner(s) of the Land or any part thereof, or interest therein, and their respective heirs, personal representatives, successors and assigns, but the same are not intended to create nor shall they be construed as creating any rights in or for the benefit of the general public. All present and future Unit Owners, tenants and occupants of Units shall be subject to and shall comply with the provisions of this Declaration and such Articles, By-Laws and applicable rules and regulations, as they may be amended from time to time. The acceptance of a deed or conveyance or the entering into of a lease, or the entering into occupancy of any Unit, shall constitute an adoption and ratification of the provisions of this Declaration and the Articles, By-Laws and applicable rules and regulations of the Association, as they may be amended from time to time by such Unit Owner, tenant or occupant.
26. Reservation of Right to Own, Install, Provide and Maintain a Closed Circuit Television System, Telecommunications System, a Master Antennae System and Community Antennae Television System (CATV Service).
- §26.1 Developer reserves and retains to itself, its successors and assigns: i) the title to any closed circuit television system, telecommunications system, master antennae system, and related ancillary services and to the equipment including but not limited to conduits, wires, amplifiers, towers, antennae and related apparatus and electronic equipment both active and passive (the "Central System") in and upon the Condominium Property and an easement for 99 years for the placement and location of the Central System including, but not limited to conduits, wires, amplifiers, towers, antennae and related apparatus and electronic equipment, both active and passive, and ii) an easement for 99 years for ingress to and egress from the Condominium Property to service, maintain, install, repair and replace the aforesaid apparatus and equipment; and iii) the right to connect the Central System to such receiving source as Developer may in its sole discretion deem appropriate, including, without limitation, companies licensed to provide the CATV service in Dade County, for which service Developer, its successors and assigns or designees shall have the right to charge the Association and/or individual Unit Owners a reasonable fee not to exceed the maximum allowable charge for CATV service to single family residences as charged within the general vicinity.
- §26.2 The Unit Owners acknowledge that the Central System described in Section 26.1 above, includes but is not limited to the CATV services as well as the ancillary services which may include security, medical, smoke and fire alert, information retrieval and so forth. Such Central System is offered as part of Developer's endeavor to provide a total environment to the Unit Owners and enhance the "way-of-life" at Costa del Sol Project - Stage 1.

REC: 14302PG 477

27. Additional Provisions.

- §27.1 Notices. All notices to the Association required or desired hereunder or under the By-Laws of the Association shall be sent by certified mail (return receipt requested) to the Association care of its office at the Condominium, or to such other address as the Association may hereafter designate from time to time by notice in writing to all Unit Owners. Except as provided specifically in the Act, all notices to any Unit Owner shall be sent by first class mail to the Condominium address of such Unit Owner, or such other address as may have been designated by him from time to time, in writing, to the Association. All notices to mortgagees of Units shall be sent by first class mail to their respective addresses, or such other address as may be designated by them from time to time, in writing, to the Association. All notices shall be deemed to have been given when mailed in a postage-prepaid, sealed wrapper, except notice of a change of address, which shall be deemed to have been given when received, or five (5) business days after proper mailing, whichever shall first occur.
- §27.2 Interpretation. The Board of Directors of the Association shall be responsible for interpreting the provisions hereof and of any of the Exhibits attached hereto. Such interpretation shall be binding upon all parties unless wholly unreasonable. An opinion of counsel that any interpretation adopted by the Association is not unreasonable shall conclusively establish the validity of such interpretation.
- §27.3 Mortgagees. The Association shall not be responsible to any mortgagee or lienor of any Unit hereunder and may assume the Unit is free of any such mortgages or liens, unless written notice of the existence of such mortgage or lien is received by the Association.
- §27.4 Exhibits. There is hereby incorporated in this Declaration any materials contained in the Exhibits annexed hereto which under the Act are required to be part of the Declaration.
- §27.5 Signature of President and Secretary. Whenever the signature of the President of the Association is required hereunder, the signature of a Vice-President may be substituted therefor, and wherever the signature of the Secretary of the Association is required hereunder, the signature of an Assistant Secretary may be substituted therefor, provided that the same person may not execute any single instrument on behalf of the Association in two separate capacities.
- §27.6 Governing Law. Should any dispute or litigation arise between any of the parties whose rights or duties are affected or determined by this Declaration, the Exhibits annexed hereto or applicable rules and regulations adopted pursuant to such documents, as the same may be amended from time to time, said dispute or litigation shall be governed by the laws of the State of Florida.
- §27.7 Severability. The invalidity in whole or in part of any covenant or restriction, or any section, subsection, sentence, clause, phrase or word, or other provision of this Declaration, the Exhibits annexed hereto, or applicable rules and regulations adopted pursuant to such documents, as the same may be amended from time to time, shall not affect the validity of the remaining portions thereof which shall remain in full force and effect.
- §27.8 Waiver. No provisions contained in this Declaration shall be deemed to have been waived by reason of any failure to enforce the same, without regard to the number of violations or breaches which may occur.

OFF: 14302PG 478  
REC:

527.9 Ratification. Each Unit Owner, by reason of having acquired ownership (whether by purchase, gift, operation of law or otherwise), and each occupant of a Unit, by reason of his occupancy, shall be deemed to have acknowledged and agreed that all of the provisions of this Declaration, and the Articles and By-Laws of the Association, and applicable rules and regulations, are fair and reasonable in all material respects.

527.10 Execution of Documents; Attorney-in-Fact. Without limiting the generality of other Sections of this Declaration and without such other Sections limiting the generality hereof, each Owner, by reason of the acceptance of a deed to such Owner's Unit, hereby agrees to execute, at the request of the Developer and its affiliates, in order to complete the plan of development of the Costa del Sol Project - Stage 2 (of which the Condominium is a part), any and all amendments to the existing documents and as they may be hereafter amended; and each such Owner further appoints hereby and thereby the Developer as such Owner's agent and attorney-in-fact to execute, on behalf and in the name of such Owners, any and all of such documents or consents. This power of attorney is irrevocable and coupled with an interest. The provisions of this Section may not be amended without the consent of the Developer.

527.11 Gender; Plurality. Wherever the context so permits, the singular shall include the plural, the plural shall include the singular, and the use of any gender shall be deemed to include all or no genders.

527.12 Captions. The captions herein and in the Exhibits annexed hereto are inserted only as a matter of convenience and for ease of reference and in no way define or limit the scope of the particular document or any provision thereof.

IN WITNESS WHEREOF, the Developer has caused this Declaration to be duly executed and its corporate seal to be affixed this 24th day of October, 1999.

Signed, sealed and delivered in the presence of:

LEHMAN HOMES, INC.

Janet J. English

By: M. E. Salera  
M. E. SALERA, Vice President

Carol M. Center

Attest: M. J. [Signature]  
MORRIS J. WATSON, Assistant Secretary

ACKNOWLEDGEMENT

STATE OF FLORIDA :  
COUNTY OF DALLAS :

The foregoing Declaration of Condominium was acknowledged before me this 24th day of October, 1999 by M. E. SALERA and MORRIS J. WATSON, as Vice President and Assistant Secretary, respectively, of Lehman Homes, Inc., a Florida corporation, on behalf of said corporation.

Carol M. Center  
Notary Public, State of Florida

By Commission Expires:

NOTARY PUBLIC STATE OF FLORIDA  
MY COMMISSION EXPIRES: 07/01/99  
BONDED THROUGH GENERAL INSURANCE



REC: 14302PG 479

## EXHIBIT 1 TO DECLARATION OF CONDOMINIUM

COSTA DEL SOL CONDOMINIUM TLEGAL DESCRIPTION

A portion of Tract "D" of COSTA DEL SOL, according to the plat thereof recorded in Plat Book 102, at Page 45 of the Public Records of Dade County, Florida, being particularly described as follows:

Commence at the Southwest corner of the NE $\frac{1}{4}$  of Section 29, Township 53 South, Range 40 East, Dade County, Florida; thence run due East along the South line of the NE $\frac{1}{4}$  of said Section 29 for 486.21 feet; thence due North for 1070.19 feet; thence S17°30'00"W for 135.44 feet to the POINT OF BEGINNING of the parcel herein described; thence from the above established Point of Beginning continue S17°30'00"W for 5.82 feet; thence N89°37'41"W for 327.87 feet to a point on the Easterly line of a 24 foot wide interior private road, TORREMOLINUS AVENUE; thence run the following courses and distances along the said Easterly line of TORREMOLINUS AVENUE: N05°33'03"E for 266.12 feet to a point of curvature of a circular curve to the right; thence to the right along said curve having for its elements a radius of 188.00 feet and a central angle of 46°21'49" for an arc distance of 152.13 feet to a point on the boundary line of Tract "A" of said COSTA DEL SOL; thence departing the said Easterly line of TORREMOLINUS AVENUE run S07°14'27"E along the said boundary line of Tract "A" for 91.26 feet to a point on the Southerly line of a 24 foot wide interior private road, COSTA DEL SOL BOULEVARD, said point being on a curve concave to the Northeast, said point bearing S43°11'10"W from the center of said curve; thence Southeastward along the said Southerly line of COSTA DEL SOL BOULEVARD along said curve to the left having for its elements a radius of 212.01 feet and a central angle of 42°43'51" for an arc distance of 188.42 feet to a point; thence S00°22'19"W for 109.43 feet to the Point of Beginning.

NOTE: The above described parcel contains 1,000 square feet, or less.

Prepared for:  
Lennar Homes, Inc.  
July 30, 1984  
Job No. 71-4259

Prepared by:  
Jack Mueller & Associates, Inc.  
Civil Engineers & Land Surveyors  
9450 Sunset Drive, Suite 200  
Miami, Florida 33173

REC: 14302PG 480

EXHIBIT 2

Allocation of Percentage Shares of  
Common Elements, Common Expenses and Common Surplus

Each Unit shall have as an appurtenance thereto the percentage share of the Common Elements, Common Expenses and Common Surplus set forth opposite such Unit below:

COSTA DEL SOL CONDOMINIUM T

BUILDING #110

<u>UNIT</u>	<u>PERCENTAGE</u>
A	1/22
B	1/22
C	1/22
D	1/22
E	1/22
F	1/22

BUILDING #111

<u>UNIT</u>	<u>PERCENTAGE</u>
A	1/22
B	1/22
C	1/22
D	1/22

BUILDING #112

<u>UNIT</u>	<u>PERCENTAGE</u>
A	1/22
B	1/22
C	1/22
D	1/22
E	1/22
F	1/22
G	1/22

BUILDING #113

<u>UNIT</u>	<u>PERCENTAGE</u>
A	1/22
B	1/22
C	1/22
D	1/22
E	1/22

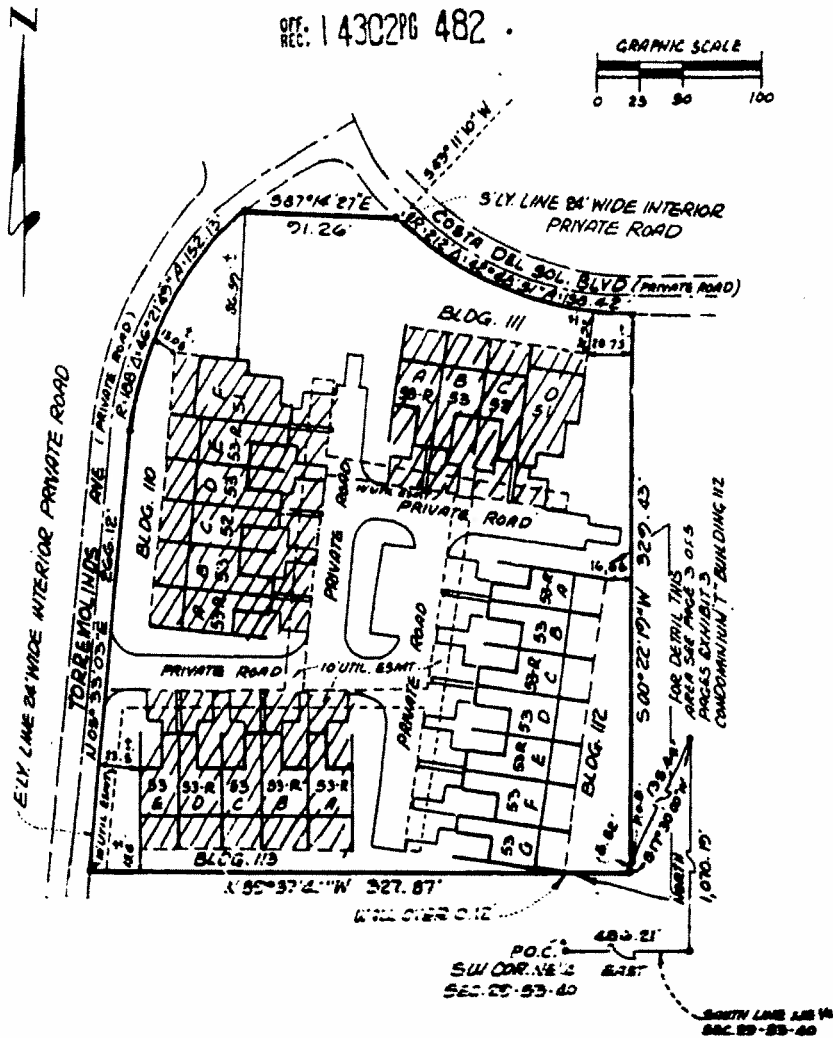

o Denotes set 1" iron pipe with cap in place.

 Denotes future building.

**NOTE:** TORREMOLINOS AVE. and COSTA DEL SOL BLVD. (not a part of CONDOMINIUM "T" property) and the private road within CONDOMINIUM "T" property are easements for ingress and egress for the use and enjoyment of all unit owners in the COSTA DEL SOL DEVELOPMENT.

EXHIBIT 3  
**SURVEY PLOT PLAN**  
**COSTA DEL SOL CONDOMINIUM "T"**  
 BUILDINGS 10, 11, 12 & 13

NOTES:

- 1. Subject to variations of 0.1% for each unit.
- 2. All elevations refer to National Geodetic Vertical Datum of 1929.
- 3. These plans and elevations are compiled from plans prepared by Bellinson Architect, P.A. and supplemented by actual field surveys.

EXHIBIT 3  
**COSTA DEL SOL CONDOMINIUM "T"**  
**BUILDING NO. 112**  
**SECOND FLOOR PLAN**

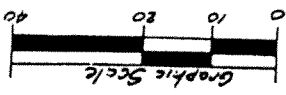
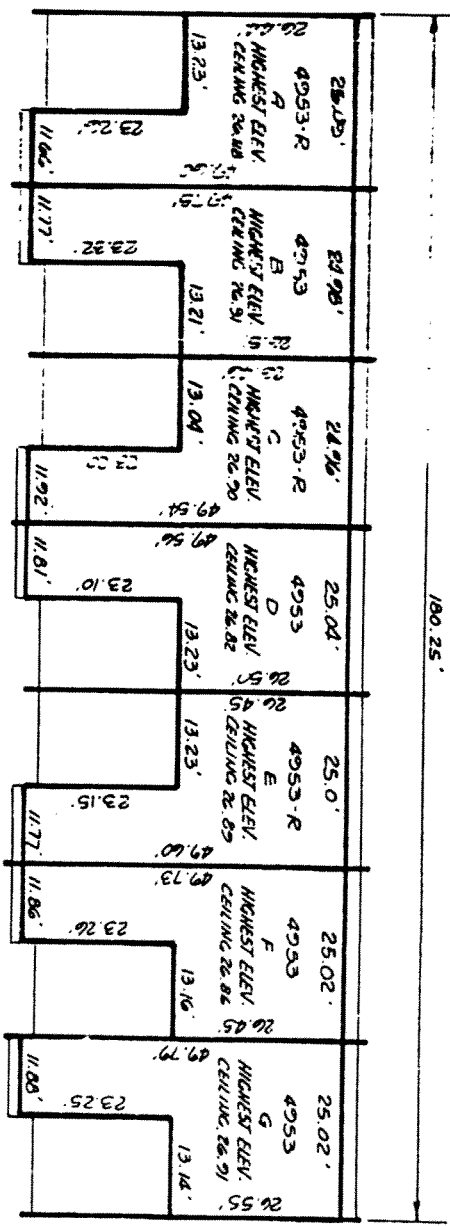

REF: 1430220 484

CONDOMINIUM PROPERTY LINE

190.25'

NOTES:

1. Subject to variations of title for each unit.
2. All elevations refer to National Geodetic Vertical Datum of 1929.
3. These plans and elevations are compiled from plans prepared by Ballinson Architect, P.A. and supplemented by actual field surveys.

DEOTES LIMITED COMMON ELEMENT

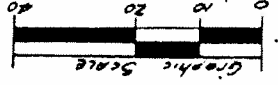
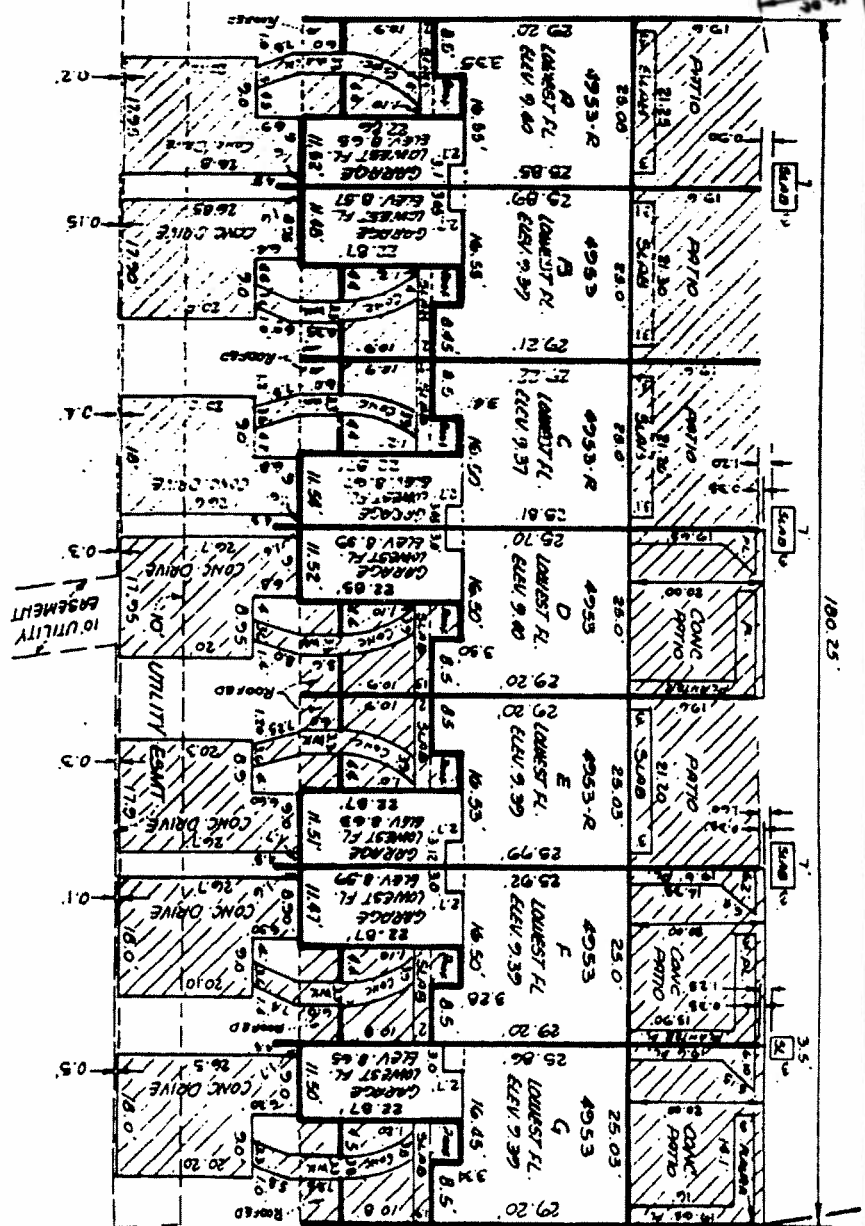

REF: 143C210 483

EXHIBIT 3  
**COSTA DEL SOL CONDOMINIUM "T"**  
**BUILDING NO. 112**  
**FIRST FLOOR PLAN**

REC: 1430276 481

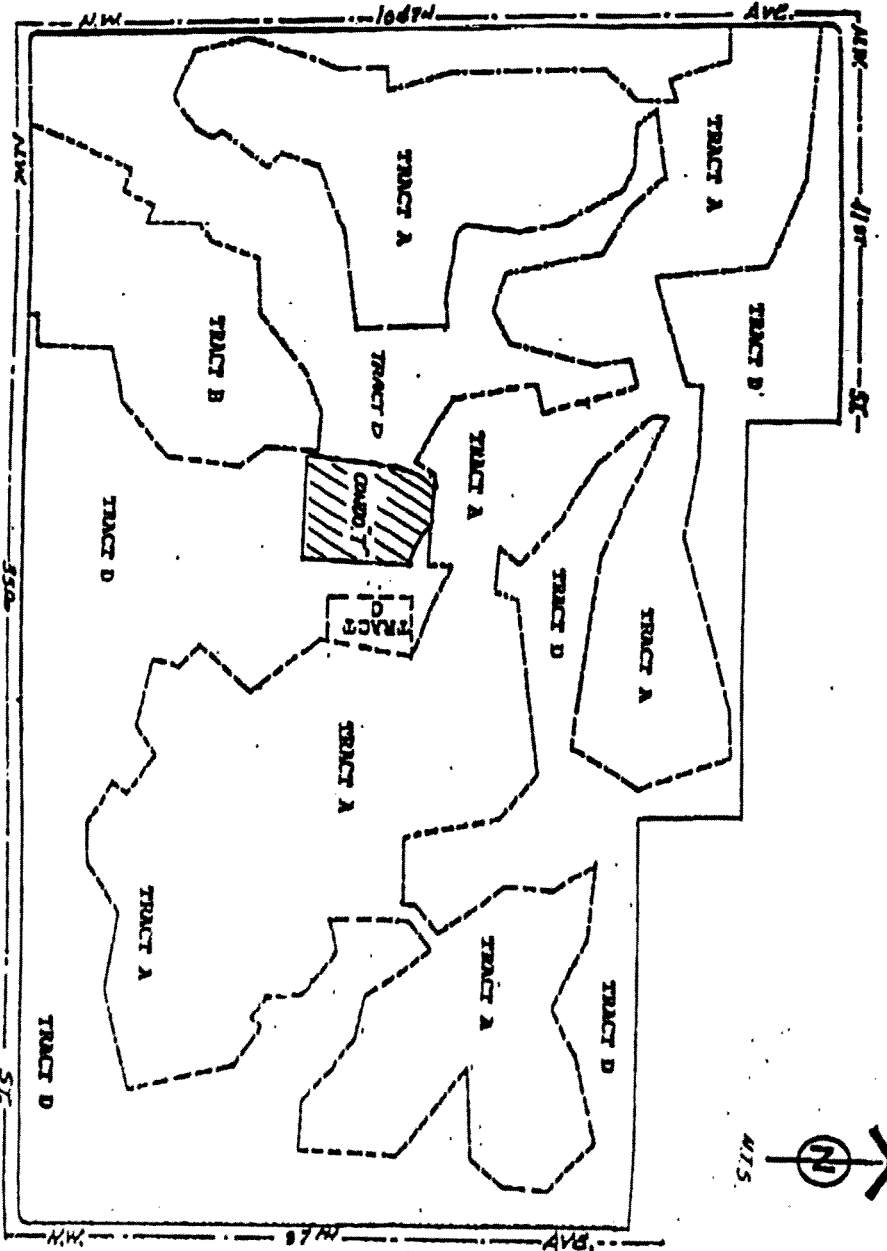

CLERK NOTE:  
FOR DECLARATION OF CONDOMINIUM  
SEE OFFICIAL RECORD BOOK 14302 PG. 443

# COSTA DEL SOL TRACT D, AMENDED P.B. 137, P. 71

EXHIBIT 3

## COSTA DEL SOL CONDOMINIUM "T" LOCATION PLAN

REF: 14302PG 485

SURVEYOR'S CERTIFICATE

The undersigned, being a surveyor authorized to practice in the state of Florida, hereby certifies that construction of the improvements within COSTA DEL SOL CONDOMINIUM "T" comprising Building 112 is substantially complete so that the materials comprising this Exhibit 3 to the Declaration of Condominium of COSTA DEL SOL CONDOMINIUM "T" together with the provisions of the Declaration describing the condominium property, is an accurate representation of the location and dimensions of the improvements comprising Building Number 112, and so that the identification, location and the dimensions of the common elements and of each unit within Building Number 112 can be determined from these materials.

The undersigned further certifies that all planned improvements for Building Number 112, including but not limited to, landscaping, utility services and access to the units within Building Number 112 and common element facilities serving Building Number 112, have been substantially completed and meets the minimum technical standards adopted by the Florida Board of Professional Land Surveyors in Chapter 21 HH-6, Florida Administrative Code.

JACK MUELLER & ASSOCIATES, INC.

By 

Robin D. Teagarden, Jr.  
Reg. Land Surveyor #2384  
State of Florida

Date October 13, 1999

SURVEYOR'S NOTES:

These plans are compiled from plans and data furnished by Lennox Homes, Inc., supplemented by such field survey and measurements as deemed necessary by Jack Mueller & Associates, Inc.

OFF.  
REC. 14302PG 495

shall be sent by mail to each Unit Owner, unless the Unit Owner waives in writing the right to receive notice of the annual meeting by mail. The delivery or mailing shall be to the address of the member as it appears on the roster of members. The posting and mailing of the notice shall be effected not less than fourteen (14) nor more than sixty (60) days prior to the date of the meeting. An officer of the Association shall provide an affidavit, to be included in the official records of the Association, affirming that notice of the Association meeting were mailed or hand delivered in accordance with this provision, to each Unit Owner at the address last furnished to the Association.

Notice of specific meetings may be waived before or after the meeting and the attendance of any member (or person authorized to vote for such member) shall constitute such member's waiver of notice of such meeting, except when his (or his authorized representative's) attendance is for the express purpose of objecting at the beginning of the meeting to the transaction of business because the meeting is not lawfully called.

**53.4 Quorum.** A quorum at members' meetings shall be attained by the presence, either in person or by proxy, of persons entitled to cast a majority of the voting interests of the entire membership. If any proposed meeting cannot be organized because a quorum has not been attained, (notwithstanding anything contained herein to the contrary) at such new meeting or meetings (if additional meetings are necessary in order to obtain the reduced quorum as hereinafter provided) the presence either in person or by proxy of persons entitled to cast 33 1/3% of the voting interests of the entire membership shall constitute a quorum at such new meeting or meetings; it being intended that in the event a majority quorum cannot be obtained at any meeting of the members, that the quorum requirements be reduced for the purposes of the new meeting or meetings to which the original meeting is adjourned only. At such new meeting or meetings, if necessary, at which a quorum exists any business may be transacted which might have been transacted at the meeting originally called.

**53.5 Voting.**

- (a) **Number of Votes.** Except when the vote is to be determined by a percentage of shares of ownership in the Condominium as contemplated in specific portions of the Declaration, in any meeting of members, the Owners of Units shall be entitled to cast one (1) vote for each Unit owned. The vote of a Unit shall not be divisible.
- (b) **Majority Vote.** The acts approved by a majority of the voting interests present in person or by proxy at a meeting at which a quorum shall have been attained shall be binding upon all Unit Owners for all purposes except where otherwise provided by law, the Declaration, the Articles or these By-Laws. As used in these By-Laws, the Articles or the Declaration, the terms "majority of the Unit Owners" and "majority of the members" shall mean a majority of the voting interests of Unit Owners and not a majority of members themselves and shall further mean more than fifty (50%) percent of the then total authorized voting interests present in person or by proxy and voting at any meeting of the Unit Owners at which a quorum shall have been attained. Similarly, if some greater percentage of members is required herein or in the Declaration, or Articles, it shall mean such greater percentage of the voting interests of members and not of the members themselves.
- (c) **Voting Member.** If a Unit is owned by one person, his right to vote shall be established by the roster of members. If a Unit is owned by more than one person, the person entitled to cast the vote for the Unit shall be designated by a



OFF: 1430270 496

certificate signed by all of the record owners of the Unit according to the roster of Unit Owners and filed with the Secretary of the Association. Such person need not be a Unit Owner, nor one of the joint owners. If a Unit is owned by a corporation, the person entitled to cast the vote for the Unit shall be designated by a Voting Certificate signed by an appropriate officer of the corporation and filed with the Secretary of the Association. Such person need not be a Unit Owner. Those Voting Certificates shall be valid until revoked or until superseded by a subsequent Voting Certificate or until a change in the ownership of the Unit concerned. A Voting Certificate designating the person entitled to cast the vote for a Unit may be revoked if by a record owner of an undivided interest in the Unit. If a Voting Certificate designating the person entitled to cast the vote for a Unit for which the Voting Certificate is required is not on file or has been revoked, the vote of the Owner(s) of such Unit shall not be considered in determining whether a quorum is present, nor for any other purpose, and the total number of authorized votes in the Association shall be reduced accordingly until the Voting Certificate is filed, except if the Unit is owned jointly by a husband and wife, they may, without being required to do so, designate a voting member in the manner provided above. Such designee need not be a Unit Owner. In the event a husband and wife do not designate a voting member, the following provisions shall apply:

- (i) If both are present at a meeting and are unable to concur in their decision upon any subject requiring a vote, they shall lose their right to vote on that subject at that meeting, and their vote shall not be considered in determining whether a quorum is present on that subject at the meeting (and the total number of authorized votes in the Association shall be reduced accordingly for such subject only).
- (ii) If only one is present at a meeting, the person present shall be counted for purposes of a quorum and may cast the Unit vote just as though he or she owned the Unit individually, and without establishing the concurrence of the absent person.
- (iii) If both are present at a meeting and concur, either one may cast the Unit vote.

**93.6 Proxies.** Votes may be cast in person or by proxy. A proxy may be made by any person entitled to vote, but shall only be valid for the specific meeting for which originally given and any lawful adjourned meetings thereof. In no event shall any proxy be valid for a period longer than ninety (90) days after the date of the first meeting for which it was given. Every proxy shall be revocable at any time at the pleasure of the person executing it. A proxy must be in writing, signed by the person authorized to cast the vote for the Unit (as above described), specify the date, time and place of the meeting for which it is given and be filed with the Secretary before the appointed time of the meeting, or before the time at which the meeting is adjourned. Holders of proxies need not be Unit Owners.

**93.7 Adjourned Meetings.** If any proposed meeting cannot be organized because a quorum has not been attained, the members who are present, either in person or by proxy, may adjourn the meeting from time to time until a reduced quorum as provided in Section 9.4 hereof is present, provided notice of the newly scheduled meeting is given in the manner required for the giving of notice of a meeting. The notice of the newly scheduled meeting shall provide, for among other things, that the quorum requirement has been reduced; and that a quorum shall be attained by the presence

REC: 1430270 497

either in person or by proxy of persons entitled to cast 33-1/3% of the voting interests of the entire membership. Proxies given for the adjourned meeting shall be valid for the newly scheduled meeting unless revoked for reasons other than the new date of the meeting.

**§3.8 Order of Business.** If a quorum has been attained, the order of business at annual members' meetings, and, if applicable, at other members' meetings, shall be:

- (a) Call to order by President;
- (b) Appointment by the President of a chairman of the meeting (who need not be a member or a director);
- (c) Proof of notice of the meeting or waiver of notice;
- (d) Reading of minutes;
- (e) Reports of officers;
- (f) Reports of committees;
- (g) Appointment of inspectors of election;
- (h) Determination of number of Directors;
- (i) Election of Directors;
- (j) Unfinished business;
- (k) New business;
- (l) Adjournment.

Such order may be waived in whole or in part by direction of the chairman.

**§3.9 Minutes of Meetings.** The minutes of all meetings of Unit Owners shall be kept in a book available for inspection by Unit Owners or their authorized representatives and Board members at any reasonable time. The Association shall retain these minutes for a period of not less than seven (7) years.

**§3.10 Action Without a Meeting.** Anything to the contrary herein notwithstanding, to the extent lawful, any action required to be taken at any annual or special meeting of members, or any action which may be taken at any annual or special meeting of such members shall be taken at a duly noticed meeting of members; except that any action may be taken without a meeting, without prior notice and without a vote of a consent in writing, setting forth the action so taken shall be signed by the members (or persons authorized to cast the vote of any such member as elsewhere herein set forth) having not less than the minimum number of voting interests that would be necessary to attain a quorum, or, with respect to certain matters where a higher percentage of members are required, such number of voting interests that would be necessary to approve such matters. Within ten (10) days after obtaining such authorization by written consent, notice must be given to members who have not consented in writing. The notice shall fairly summarize the material features of the authorized action.

#### 4. Directors.

**§4.1 Membership.** The affairs of the Association shall be governed by a Board of not less than three (3) nor more than five (5) directors, the exact number to be determined in the first instance in the Articles and thereafter, except as provided herein, from time

OFF.  
REC: 1430270 498

to time, upon the vote of the majority of the voting interests of the membership. Directors need not be Unit Owners.

**54.2 Election of Directors.** The election of Directors shall be conducted in the following manner:

- (a) Election of Directors shall be held at the annual members' meeting, except as provided herein to the contrary.
- (b) Nominations for Directors and additional directorships created at the meeting shall be made from the floor.
- (c) The election shall be by written ballot (unless dispensed with by majority consent of the voting interests of the members represented at the meeting) and by a plurality of the votes cast, each person voting shall be entitled to cast his vote for each of as many nominees as there are vacancies to be filled. There shall be no cumulative voting.

**54.3 Vacancies and Removal.**

- (a) Except as to vacancies resulting from removal of Directors by members, vacancies in the Board of Directors occurring between annual meetings of members shall be filled by the remaining Directors, provided that all vacancies in directorships to which Directors were appointed by the Developer pursuant to the provisions of Section 4.17 hereof shall be filled by the Developer without the necessity of any meeting.
- (b) Until a majority of the Directors are elected by the members other than the Developer, neither the first Directors replacing them nor any Directors named by the Developer shall be subject to removal by members other than the Developer. The first Directors and Directors replacing them may be removed and replaced by the Developer without the necessity of any meeting.
- (c) Subject to the provisions of the Act and Section 4.17 of these By-Laws, any member of the Board may be recalled and removed from office with or without cause by the vote or agreement in writing by a majority of all the voting interests. A special meeting of the Unit Owners to recall a member or members of the Board may be called by ten percent (10%) of the voting interests giving notice of the meeting as required for a meeting of Unit Owners, and the notice shall state the purpose of the meeting.
  - (i) If the recall is approved by a majority of all voting interests by a vote at a meeting, the recall shall be effective immediately, and the recalled member or members on the Board shall turn over to the Board any and all records of the Association in his or their possession, within 72 hours after the meeting.
  - (ii) If the proposed recall is by an agreement in writing by a majority of all voting interests, the agreement in writing shall be served on the Association by certified mail. The Board shall call a meeting of the Board within 72 hours after receipt of the agreement in writing and shall either certify the written agreement to recall a member or members of the Board, in which case such member or members shall be recalled effective immediately and shall turn over to the Board within 72 hours, any and all records of the Association in his or their possession, or proceed as described in subparagraph (iii) below.

REF: 143C270 499

- (iii) If the Board determines not to certify the written agreement to recall a member or members of the Board, or if the recall by a vote at a meeting is disputed, the Board shall, within 72 hours, file with the Division of Florida Land Sales, Condominiums and Mobile Homes (the "Division"), a petition for binding arbitration pursuant to the procedures of the Act. For purposes of this Section 4.3(c), the Unit Owners who voted at the meeting or who executed the agreement in writing shall constitute one party under the petition for arbitration. If the arbitrator certifies the recall as to any member or members of the Board, the recall shall be effective upon service of the final order of arbitration upon the Association. If the Association fails to comply with the order of the arbitrator, the Division may take appropriate action pursuant to the Act. Any member or members so recalled shall deliver to the Board any and all records of the Association in his or their possession within 72 hours of the effective date of the recall.
- 54.4 Term. Except as provided herein to the contrary, the term of each Director's service shall extend until the next annual meeting of the members and subsequently until his successor is duly elected and qualified, or until he is removed in the manner elsewhere provided.
- 54.5 Organizational Meeting. The organizational meeting of newly-elected or appointed members of the Board of Directors shall be held within ten (10) days of their election or appointment at such place and time as shall be fixed by the Directors at the meeting at which they were elected or appointed, and no further notice to the Board of the organizational meeting shall be necessary.
- 54.6 Regular Meetings. Regular meetings of the Board of Directors may be held at such time and place as shall be determined, from time to time, by a majority of the Directors. Notice of regular meetings shall be given to each Director, personally or by mail, telephone or telegraph, and shall be transmitted at least three (3) days prior to the meeting. Regular meetings of the Board of Directors shall be open to all Unit Owners and notice of such meetings shall be posted conspicuously on the Condominium Property at least forty-eight (48) hours in advance for the attention of the members of the Association, except in the event of an emergency, provided that Unit Owners shall not be permitted to participate and need not be recognized at any such meeting.
- 54.7 Special Meetings. Special meetings of the Directors may be called by the President and must be called by the President or Secretary at the written request of one-third (1/3) of the Directors. Notice of the meeting shall be given personally or by mail, telephone or telegraph, which notice shall state the time, place and purpose of the meeting and shall be transmitted not less than three (3) days prior to the meeting. Special meetings of the Board of Directors shall be open to all Unit Owners and notice of a special meeting shall be posted conspicuously on the Condominium Property at least forty-eight (48) hours in advance for the attention of the members of the Association, except in the event of an emergency, provided that Unit Owners shall not be permitted to participate and need not be recognized at any such meeting.
- 54.8 Waiver of Notice. Any Director may waive notice of a meeting before or after the meeting and that waiver shall be deemed equivalent to the due receipt by said Director of notice. Attendance by any Director at a meeting shall constitute a waiver of notice of such meeting, except when his attendance is for the express purpose of objecting at the beginning of the meeting to

OFF: 143C2PG 500  
REC:

the transaction of business because the meeting is not lawfully called.

- §4.9 Quorum. A quorum at Directors' meetings shall consist of a majority of the entire Board of Directors. The acts approved by a majority of those present at a meeting at which a quorum is present shall constitute the acts of the Board of Directors except when approval by a greater number of Directors is specifically required by the Declaration, the Articles or these By-Laws.
- §4.10 Adjourned Meetings. If at any proposed meeting of the Board of Directors there is less than a quorum present, the majority of those present may adjourn the meeting from time to time until a quorum is present, provided notice of such newly scheduled meeting is given as required hereunder. At any newly scheduled meeting, any business that might have been transacted at the meeting as originally called may be transacted without further notice.
- §4.11 Joinder in Meeting by Approval of Minutes. The joinder of a Director in the action of a meeting by signing and concurring in the minutes of that meeting shall constitute the approval of that Director of the business conducted at the meeting.
- §4.12 Presiding Officer. The presiding officer at the Directors' meetings shall be the President (who may, however, designate any other person to preside). In the absence of the presiding officer, the Directors present may designate any person to preside.
- §4.13 Order of Business. If a quorum has been attained, the order of business at Director's meetings shall be:
- (a) Proof of due notice of meeting;
  - (b) Reading and disposal of any unapproved minutes;
  - (c) Reports of officers and committees;
  - (d) Election of officers;
  - (e) Unfinished business;
  - (f) New business;
  - (g) Adjournment.
- Such order may be varied in whole or in part by direction of the presiding officer.
- §4.14 Minutes of Meetings. The minutes of all meetings of the Board of Directors shall be kept in a book available for inspection by Unit Owners, or their authorized representatives, and Board members at any reasonable time. The Association shall retain these minutes for a period of not less than seven (7) years.
- §4.15 Action Without a Meeting. Anything to the contrary herein notwithstanding, and to the extent lawful, any action required to be taken at a meeting of the Directors, or any action which may be taken at a meeting of Directors or a committee thereof, may be taken without a meeting if a consent in writing setting forth the action so to be taken signed by all of the Directors or all the members of the committee, as the case may be, is filed in the minutes of the proceedings of the Board or of the committee. Such consent shall have the same effect as a unanimous vote. No prior notice of such intended action shall be required to be given to the Directors or to the Unit Owners. Notice of the taking of such action pursuant hereto shall, however, be posted conspicuously on the Condominium Property for the attention of Owners after such action shall have been effected. Such notice shall fairly summarize the material features of the action so taken.

OFF. REC. 1430270 501

54.16 Executive Committee; Other Committees. The Board of Directors may, by resolution duly adopted, appoint an Executive Committee to consist of three (3) or more members of the Board of Directors. Such Executive Committee shall have and may exercise all of the powers of the Board of Directors in management of the business and

affairs of the Condominium during the period between the meetings of the Board of Directors insofar as may be permitted by law, except that the Executive Committee shall not have power (a) to determine the Common Expenses required for the affairs of the Condominium, (b) to determine the Assessments or Special Assessments payable by the Unit Owners to meet the Common Expenses of the Condominium, (c) to adopt or amend any rules and regulations covering the details of the operation and use of the Condominium Property, or (d) to exercise any of the powers set forth in paragraph (g) and (p) of Section 5 below.

The Board may, by resolution, also create other committees and appoint persons to such committees and invest in such committees such powers and responsibilities as the Board shall deem advisable.

54.17 Proviso. Notwithstanding anything to the contrary contained in this Section 4 or otherwise, the Board shall consist of three (3) directors during the period that the Developer is entitled to appoint a majority of the directors, as hereinafter provided. The Developer shall have the right to appoint all of the members of the Board of Directors until Unit Owners other than the Developer own fifteen (15%) percent or more of the Units that will be operated ultimately by the Association; then Unit Owners other than the Developer shall be entitled to elect not less than one-third (1/3) of the members of the Board of Directors. Unit Owners other than the Developer are entitled to elect not less than a majority of the members of the Board of Directors (a) three (3) years after fifty (50%) percent of the Units that will be operated ultimately by the Association have been conveyed to purchasers, (b) three (3) months after ninety (90%) percent of the Units that will be operated ultimately by the Association have been conveyed to purchasers, (c) when all of the Units that will be operated ultimately by the Association have been completed, some of them have been conveyed to purchasers and none of the others are being offered for sale by the Developer in the ordinary course of business, (d) when some of the Units have been conveyed to purchasers and none of the others are being constructed or offered for sale by the Developer in the ordinary course of business, (e) or five (5) years after closing of title to the first Unit that will be operated ultimately by the Association, whichever occurs first. The Developer is entitled (but not obligated) to elect at least one (1) member of the Board of Directors as long as the Developer holds for sale in the ordinary course of business five (5%) percent of the Units that will be operated ultimately by the Association.

The Developer may turn over control of the Association to Unit Owners other than the Developer prior to such dates in its sole discretion by causing all of its appointed Directors to resign, whereupon it shall the affirmative obligation of Unit Owners other than the Developer to elect Directors and assume control of the Association. Provided at least thirty (30) days' notice of Developer's decision to cause its appointees to resign is given to Unit Owners, neither the Developer nor such appointees shall be liable in any manner in connection with such resignations even if the Unit Owners other than the Developer refuse or fail to assume control.

Within sixty (60) days after the Unit Owners other than the Developer are entitled to elect a member or members of the Board of Directors, or if the Developer has elected to accelerate such events aforesaid, the Association shall call, and give not less

OFF.  
REC. 1430210 502

than thirty (30) days' nor more than forty (40) days' notice of a meeting of the Unit Owners to elect such member or members of the Board of Directors. The meeting may be called and the notice given by any Unit Owner if the Association fails to do so.

Within a reasonable time after Unit Owners other than the Developer elect a majority of the members of the Board of Directors of the Association (but not more than sixty (60) days after such event), Developer shall relinquish control of the Association and, at the Developer's expense, deliver to the Association all property of the Unit Owners and of the Association held by or controlled by the Developer, including but not limited to the following items, if applicable:

- (a) The original or a photocopy of the recorded Declaration of Condominium and all amendments thereto. If a photocopy is provided, the Developer must certify by affidavit that it is a complete copy of the actual recorded Declaration;
- (b) A certified copy of the Articles of Incorporation for the Association;
- (c) A copy of the By-Laws of the Association;
- (d) The minute books, including all minutes, and other books and records of the Association;
- (e) Any rules and regulations which have been adopted;
- (f) Resignations of resigning officers and Board members who were appointed by the Developer;
- (g) The financial records, including financial statements of the Association, and source documents since the incorporation of the Association through the date Developer relinquishes control of the Association. The records shall be reviewed by an independent certified public accountant. The minimum report required shall be a review in accordance with generally accepted accounting standards as defined by rule by the Board of Accounting. The accountant performing the review shall examine to the extent necessary supporting documents and records, including the cash disbursements and related paid invoices to determine if expenditures were for Association purposes, and billings, cash receipts and related records to determine that the Developer was charged and paid the proper amounts of Assessments.
- (h) Association funds or the control thereof;
- (i) All tangible personal property that is the property of the Association or is or was represented by the Developer to be part of the Common Elements or is ostensibly part of the Common Elements, and an inventory of such property;
- (j) A copy of the plans and specifications utilized in the construction or remodeling of Improvements and the supplying of equipment, and for the construction and installation of all mechanical components servicing the Improvements and the Condominium Property, with a Certificate, in affidavit form, of an officer of the Developer or an architect or engineer authorized to practice in Florida, that such plans and specifications represent, to the best of their knowledge and belief, the actual plans and specifications utilized in the construction and improvement of the Condominium Property and the construction and installation of the mechanical components servicing the Improvements and the Condominium Property;
- (k) Insurance policies;

OFF.  
REC: 14302PG 503

- (l) Copies of any Certificates of Occupancy which may have been issued for the Condominium Property;
- (m) Any other permits issued by governmental bodies applicable to the Condominium Property in force or issued within one (1) year prior to the date the Unit Owners take control of the Association;
- (n) All written warranties of contractors, subcontractors, suppliers and manufacturers, if any, that are still effective;
- (o) A roster of Unit Owners and their addresses and telephone numbers, if known, as shown on the Developer's records;
- (p) Leases of the Common Elements and other Leases to which the Association is a party, if applicable;
- (q) Employment contracts or service contracts in which the Association is one of the contracting parties, or service contracts in which the Association or Unit Owners have an obligation or responsibility, directly or indirectly, to pay some or all of the fee or charge of the person or persons performing the service; and
- (r) All other contracts to which the Association is a party.

**54.18 Attendance.** A Director who is present at any Director's meeting at which action on any corporate matter is taken shall be presumed to have assented to the action taken, unless he votes against such action or abstains from voting in respect thereto because of an asserted conflict of interest.

**5. Powers and Duties.** The Board of Directors shall have the powers and duties necessary for the administration of the affairs of the Condominium and may take all acts, through the proper officers of the Association, in exercising such powers, except such acts which by law, the Declaration, the Articles or these By-Laws may not be delegated to the Board of Directors by the Unit Owners. Such powers and duties of the Board of Directors shall include, without limitation (except as limited elsewhere herein) the following:

- (a) Operating and maintaining the Common Elements.
- (b) Determining the expenses required for the operation of the Condominium and the Association.
- (c) Collecting the Assessments and Special Assessments from Unit Owners.
- (d) Employing and designating the personnel necessary for the maintenance and operation of the Common Elements.
- (e) Adopting and amending rules and regulations concerning the details of the operation and use of the Condominium Property, subject to a right of the Unit Owners to overrule the Board as provided in §10 hereof.
- (f) Maintaining bank accounts on behalf of the Association and designating the signatories required therefor.
- (g) Purchasing, leasing, holding or otherwise acquiring Units or other property in the name of the Association or its designee for the use and benefit of its members.
- (h) Purchasing Units at foreclosure or other judicial sales, in the name of the Association or its designee.
- (i) Selling, leasing, mortgaging or otherwise dealing with Units



REF: 14332PG 504

- acquired by, and subleasing Units leased by, the Association or its designee.
- (j) Organizing corporations and appointing persons to act as designees of the Association in acquiring title to or leasing Units or other property.
- (k) Obtaining and maintaining adequate insurance to protect the Association, the Association Property, if any, and the Condominium Property.
- (l) Making repairs, additions and improvements to, or alterations of, the Condominium Property, and repairs to and restoration of the Condominium Property in accordance with the provisions of the Declaration after damage or destruction by fire or other casualty or as a result of condemnation or eminent domain proceedings or otherwise.
- (m) Enforcing obligations of the Unit Owners, allocating profits and expenses and taking such other actions as shall be deemed necessary and proper to the sound management of the Condominium.
- (n) Levying fines where appropriate against Unit Owners for violations of the rules and regulations established by the Association to govern the conduct of such Unit Owners.
- (o) Purchasing or leasing Units for use by resident superintendents.
- (p) Borrowing money on behalf of the Condominium when required in connection with the operation, care, upkeep and maintenance of the Common Elements or the acquisition of property, and granting mortgages on and/or security interests in Association Property; provided, however, that the consent of the Owners of at least two-thirds (2/3) of the voting interests of the Units represented at a meeting at which a quorum has been obtained in accordance with the provisions of these By-Laws shall be required for the borrowing of any sum in excess of \$50,000.00. If any sum borrowed by the Board of Directors on behalf of the Condominium pursuant to the authority contained in this subparagraph is not repaid by the Association, a Unit Owner who pays to the creditor such portion thereof as his interest in the Common Elements bears to the interest of all the Unit Owners in the Common Elements shall be entitled to obtain from the creditor a release of any judgment or other lien which said creditor shall have filed or shall have the right to file on which will affect such Unit Owner's Unit.
- (q) Contracting for the management and maintenance of the Condominium Property and authorizing a management agent (which may be an affiliate of the Developer) to assist the Association in carrying out its powers and duties by performing such functions as the submission of proposals, collection of Assessments, Special Assessments, preparation of records, re-enforcement of rules, and maintenance, repair and replacement of the Common Elements which funds as shall be made available by the Association for such purposes. The Association shall, however, retain at all times the powers and duties granted by the Condominium Documents and the Act, including but not limited to the making of Assessments, Special Assessments, promulgation of rules and the execution of contracts on behalf of the Association.
- (r) At its discretion, authorizing Unit Owners or other persons to use portions of the Common Elements or Association Property for private parties and gatherings and impose reasonable charges for such private use provided such use is the subject of a lease between the Association and the Unit Owner.
- (s) At its discretion, instituting or authorizing voluntary binding arbitration of internal disputes arising from the operation of the Condominium among Unit Owners, the Association, their agents and

REF: 14302PG 505

assigns in accordance with the rules of procedure promulgated by the Department of Business Regulation.

- (l) Imposing a lawful fee in connection with the approval of the transfer, sale, lease, or sublease of Units.
- (u) Subject to the prior consent of the Developer, which consent shall be required until December 31, 1999 or until Developer has conveyed title to the last Condominium Unit to be built in Costa del Sol Project - Stage 2, or such earlier time, as may be determined in the sole discretion of Developer, to grant, modify or move any easement, subject to the provisions of the easement, without the joinder of any Unit Owners, if the easement constitutes part of or crosses the Common Elements.
- (v) Exercising (i) all powers specifically set forth in the Declaration, the Articles, these By-Laws, and in the Act, and (ii) all powers incidental thereto, and all other powers of a Florida corporation not for profit under Florida Statutes, Chapters 607 and 617, (as they exist on the date hereof and as hereafter renumbered), as applicable, if not inconsistent with the Act.
- (w) Levying Assessments for Common Expenses against Unit Owners for their share of the items in the budget, and/or Special Assessments for Common Expenses for emergencies for the Association.
- (x) Maintaining, since the inception of the Association, a copy of each of the following, where applicable, which shall constitute the official records of the Association:
  - (1) The plans, permits, warranties, and other items provided by the Developer pursuant to Section 4.17 of these By-Laws;
  - (2) A photocopy of the recorded declaration of each condominium operated by the Association and all amendments thereto;
  - (3) A photocopy of the recorded By-Laws of the Association and all amendments thereto;
  - (4) A certified copy of the Articles of Incorporation of the Association or other documents creating the Association and all amendments thereto;
  - (5) A copy of the current rules of the Association;
  - (6) A book or books containing the minutes of all meetings of the Association, of the Board of Directors, and of Unit Owners, which minutes shall be retained for a period of not less than 7 years;
  - (7) A current roster of all Unit Owners, their mailing addresses, Unit identifications, Voting Certificates, and if known, telephone numbers;
  - (8) All current insurance policies of the Association and condominiums operated by the Association;
  - (9) A current copy of any management agreement, lease, or other contract to which the Association is a party or under which the Association or the Unit Owner's have an obligation or responsibility;
  - (10) Bills of sale or transfer for all property owned by the Association;
  - (11) Accounting records for the Association and separate accounting records for each condominium it operates, according to good accounting practices. All accounting records shall be maintained for a period of not less than 7

REF: 14302PG 506

years. The accounting records shall include, but are not limited to:

- (a) Accurate, itemized, and detailed records of all receipts and expenditures.
  - (b) A current account and a monthly, bimonthly, or quarterly statement of the account for each unit designating the name of the Unit Owner, the due date and amount of each Assessment, Special Assessment, if any, the amount paid upon the account, and the balance due.
  - (c) All audits, reviews, accounting statements, and financial reports of the Association or Condominium.
  - (d) All contracts for work to be performed. Bids for work to be performed shall also be considered official records and shall be maintained for a period of 1 year.
- (12) Voting proxies, which shall be maintained for a period of 1 year from the date of the meeting for which the proxy was given.
- (13) All rental records where the Association is acting as agent for the rental of Units.

The official records of the Association shall be maintained in the county in which the Condominium is located and be open to inspection by any Association member or the authorized representative of such member at all reasonable times. Failure to permit inspection of the Association records as provided herein entitles any person prevailing in an enforcement action to recover reasonable Attorneys' fees from the person in control of the records who, directly or indirectly, knowingly denies access to the records for inspection. The right to inspect the records includes the right to make or obtain copies, at the reasonable expense, if any, of the Association member.

### 3. Officers.

**§6.1 Executive Officers.** The executive officers of the Association shall be a President, who shall be a Director, a Vice President, who shall be a Director, a Treasurer, a Secretary and an Assistant Secretary (none of whom need be Directors), all of whom shall be elected by the Board of Directors and who may be preemptorily removed at any meeting by concurrence of a majority of all of the Directors. A person may hold more than one office, except that the President may not also be the Secretary or Assistant Secretary. No person shall sign an instrument or perform an act in the capacity of more than one office. The Board of Directors from time to time shall elect such other officers and designate their powers and duties as the Board shall deem necessary or appropriate to manage the affairs of the Association. Officers need not be Unit Owners.

**§6.2 President.** The President shall be the chief executive officer of the Association. He shall have all of the powers and duties that are usually vested in the office of president of an association.

**§6.3 Vice President.** The Vice President shall exercise the powers and perform the duties of the President in the absence or disability of the President. He also shall assist the President and exercise such other powers and perform such other duties as are incident to the office of an association and as shall otherwise be prescribed by the Directors.

**§6.4 Secretary.** The Secretary shall keep the minutes of all proceedings of the Directors and the members. He shall attend to the giving of all notices to the members and Directors and other

OFF.  
REC: 14302PG 507

notices required by law. He shall have custody of the seal of the Association and shall affix it to instruments requiring the seal when duly signed. He shall keep the records of the Association, except those of the Treasurer, and shall perform all other duties incident to the office of the secretary of an association and as may be required by the Directors or the President.

**§6.5 Assistant Secretary.** The Assistant Secretary shall exercise the powers and perform the duties of the Secretary in the absence or disability of the Secretary.

**§6.6 Treasurer.** The Treasurer shall have custody of all property of the Association, including funds, securities and evidences of indebtedness. He shall keep books of account for the Association in accordance with good accounting practices, which together with substantiating papers, shall be made available to the Board of Directors for examination at reasonable times. He shall submit a treasurer's report to the Board of Directors at reasonable intervals and shall perform all other duties incident to the office of treasurer. All monies and other valuable effects shall be kept for the benefit of the Association in such depositories as may be designated by a majority of the Board of Directors.

7. **Compensation.** Neither Directors nor officers shall receive compensation for their services as such, but this provision shall not preclude the Board of Directors from employing a Director or officer as an employee of the Association, nor preclude contracting with a Director or officer for the management of the Condominium or for any other service to be supplied by such Director or officer. Directors and officers shall be compensated for all actual and proper out of pocket expenses relating to the proper discharge of their respective duties.
8. **Resignations.** Any Director or officer may resign his post at any time by written resignation, delivered to the President or Secretary, which shall take effect upon its receipt unless a later date is specified in the resignation, in which event the resignation shall be effective from such date unless withdrawn. The acceptance of a resignation shall not be required to make it effective.
9. **Fiscal Management.** The provisions for fiscal management of the Association set forth in the Declaration and Articles shall be supplemented by the following provisions:

**§6.1 Budget.**

- a) **Adoption by Board; Items.** The Board of Directors shall from time to time, and at least annually, prepare a budget for the Condominium which shall detail all accounts and items of expenses and contain at least all items set forth in Section 16.504(2) of the Act, in applicable; determine the amount of Assessments payable by the Unit Owners and allocate and assess expenses among the Unit Owners in accordance with the provisions hereof and of the Declaration. In addition to annual operating expenses, the budget shall include reserve accounts for capital expenditures and deferred maintenance. These accounts shall include, but not be limited to, roof replacement, building painting and pavement resurfacing. The amount of reserves shall be computed by means of a formula which is based upon estimated life and estimated replacement cost of each reserve item. Reserves shall not be required if the members of the Association have, by a majority of the voting interests present at a duly called meeting of members, determined for a specific fiscal year to provide no reserves or reserves less adequate than required hereby. If a meeting of the Unit Owners has been called to provide no reserves or reserves less adequate than required, and such result is not obtained or a quorum is not attained, the reserves as included in the budget, shall go into effect. The adoption

REF: 14302PG 508

of a budget for the Condominium shall comply with the requirements hereinafter set forth:

- (i) Notice of Meeting. A copy of the proposed budget of Common Expenses shall be mailed to each Unit Owner not less than fourteen (14) days prior to the meeting of the Board of Directors at which the budget will be considered, together with a notice of that meeting indicating the time and place of such meetings. The meeting shall be open to Unit Owners, provided that such Unit Owners shall not have the right to participate and need not be recognized at such meeting.
- (ii) Special Membership Meeting. If a budget is adopted by the Board of Directors which requires Assessments against such Unit Owners in any year exceeding one hundred fifteen (115%) percent of such Assessments for the preceding year, as hereinafter defined, upon written application of ten (10%) percent of the voting interests to the Board of Directors, a special meeting of Unit Owners shall be held within thirty (30) days of delivery of such application to the Board of Directors. Each Unit Owner shall be given at least ten (10) days' notice of said meeting. At the special meeting, Unit Owners shall consider and adopt a budget. The adoption of said budget shall require a vote of not less than a majority of all the voting interests of the Unit Owners (including the voting interests of the Developer).
- (iii) Determination of Budget Amount. In determining whether a budget requires Assessments against Unit Owners in any year exceeding one hundred fifteen (115%) percent of Assessments for the preceding year, there shall be excluded in the computations any authorized provisions for reasonable reserves made by the Board of Directors in respect of repair or replacement of the Condominium Property or in respect of anticipated expenses of the Association which are not anticipated to be incurred on a regular or annual basis, and there shall be excluded from such computation Assessments for improvements to the Condominium Property and expenses which are unique to specific Unit Owners.
- (iv) Provision. As long as the Developer is in control of the Board of Directors of the Association, such Board shall not impose an Assessment for a year greater than one hundred fifteen (115%) percent of the prior year's Assessment, as herein defined, without the approval of Unit Owners owning a majority of the voting interests including the voting interests of the Developer.
- (v) Adoption by Membership. In the event that the Board of Directors shall be unable to adopt a budget in accordance with the requirements of Section 3.03(a) above, the Board of Directors may call a special meeting of Unit Owners for the purpose of considering and adopting such budget, which meeting shall be called and held in the manner provided for special meetings in Section 3.03(a), or propose a budget in writing to the members. If such budget is approved by a majority of the voting interests at the meeting or in writing, upon ratification by a majority of the Board of Directors, it shall become the budget for such year.
- (vi) Failure of Quorum or to Adopt Substitute Budget. If a meeting of the Unit Owners has been called and a quorum is not attained or a substitute budget is not adopted by the Unit Owners, the budget adopted by the Board of Directors shall go into effect as scheduled.

OFF. REC. 1430276 509

- 59.2 Assessments. Assessments against the Unit Owners for their share of the items of the budget shall be made for the applicable calendar year annually in advance on or before December 20th preceding the year for which the Assessments are made. Such Assessments shall be due in equal installments, payable in advance on the first day of each month (or each quarter at the election of the Board) of the year for which the Assessments are made. If an annual Assessment is not made as required, an Assessment shall be presumed to have been made in the amount of the last prior Assessment, and monthly (or quarterly) installments on such Assessment shall be due upon each installment payment date until changed by an amended Assessment. In the event the annual Assessment proves to be insufficient, the Budget and Assessment may be amended at any time by the Board of Directors. Unpaid Assessments for the remaining portion of the calendar year for which an amended Assessment is made shall be payable in as many equal installments as there are full months (or quarters) of the calendar year left as of the date of such amended Assessment, each such monthly (or quarterly) installment to be paid on the first day of the month (or quarter), commencing the first day of the next ensuing month (or quarter). If only a partial month (or quarter) remains, the amended Assessment shall be paid with the next regular installment in the following year, unless otherwise directed by the Board in its resolution.
- 59.3 Charges. Charges by the Association against members for other than Common Expenses shall be payable in advance. Charges for other than Common Expenses may be made only after approval of a member or when expressly provided for in the Declaration or the exhibits annexed thereto, as the same may be amended from time to time, which charges may include, without limitation, charges for the use of the Condominium Property or recreation areas, maintenance services furnished at the expense of an Owner, other services furnished for the benefit of an Owner and such charges, fines and damages and other sums due from such Owner.
- 59.4 Special Assessments for Emergencies. Special Assessments for Common Expenses for emergencies that cannot be paid from the annual Assessments for Common Expenses shall be due only after ten (10) days' notice is given to the Unit Owners concerned, and shall be paid in such manner as the Board of Directors of the Association may require in the notice of Special Assessment.
- 59.5 Depository. The depository of the Association shall be such bank or banks in the County as shall be designated from time to time by the Directors and in which the monies of the Association shall be deposited. Withdrawal of monies from these accounts shall be made only by checks signed by such person or persons as are authorized by the Directors. All sums collected by the Association from Assessments, Special Assessments, or contributions to working capital or otherwise may be commingled in a single fund or divided into more than one fund, as determined by a majority of the Board of Directors.
- 59.6 Acceleration of Assessment or Special Assessment Installments Upon Default. If a Unit Owner shall be in default in the payment of an installment upon an Assessment or Special Assessment, the Board of Directors may accelerate the remaining installments of the Assessment or Special Assessment upon notice to the Unit Owner and the then unpaid balance of the Assessment or Special Assessment shall be due upon the date stated in the notice, but not less than five (5) days after delivery of the notice to the Unit Owner, or not less than ten (10) days after the mailing of such notice to him by registered or certified mail, whichever shall first occur.
- 59.7 Fidelity Bonds. To the extent required by law, fidelity bonds in the principal sum of not less than \$25,000.00, for any officer or director shall be required by the Board of Directors for such

REC: 1430270 510

officers who control or disburse Association's funds. The premiums on such bonds shall be paid by the Association as a Common Expense.

- 59.8 Accounting Records and Reports. Written summaries of the records described in Section 5(x)(11)(a) of these By-Laws, in the form and manner specified below, shall be supplied to each Unit Owner annually.

Within sixty (60) days following the end of the fiscal year, the Board shall mail, or furnish by personal delivery, to each Unit Owner a complete financial report of actual receipts and expenditures for the previous twelve (12) months. The report shall show the amounts of receipts by accounts and receipt classifications and shall show the amounts of expenses by accounts and expense classifications, including, if applicable, but not limited to, the following:

- (a) Cost for security;
- (b) Professional and management fees and expenses;
- (c) Taxes;
- (d) Costs for recreation facilities;
- (e) Expenses for refuse collection and utility services;
- (f) Expenses for lawn care;
- (g) Costs for building maintenance and repair;
- (h) Insurance costs;
- (i) Administrative and salary expenses; and
- (j) General reserves, maintenance reserves and depreciation reserves.

- 59.9 Application of Payment. All Assessment and Special Assessment payments made by a Unit Owner shall be applied as provided herein and in the Declaration or as determined by the Board.

- 59.10 Notice of Meetings. Notice of any meeting where Special Assessments against Unit Owners are to be considered for any reason shall specifically contain a statement that Special Assessments will be considered and the nature of any such Special Assessments.

- 59.11 Limitation on Developer's Liability for Special Assessments. The Developer shall not be liable for the payment of any Special Assessments applicable to the Units it owns which relate in any way to the payment of legal or other fees to persons or entities engaged by the Association for the purpose of suing, or suing, preparing or investigating possible claims against the Developer.

10. Roster of Unit Owners. Each Unit Owner shall file with the Association a copy of the deed or other instrument showing his ownership. The Association shall maintain such information. The Association may rely upon the accuracy of such information for all purposes until notified in writing of changes therein as provided above. Only Unit owners of record on the date notice of any meeting requiring their vote is given shall be entitled to notice of and to vote at such meeting, unless prior to such meeting other Owners shall produce adequate evidence, as provided above, of their interest and shall waive in writing notice of such meeting.

REF: 1430210 511

11. Parliamentary Rules. Roberts' Rules of Order (latest edition) shall govern the conduct of the Association meetings when not in conflict with the Declaration, the Articles or these By-Laws.
12. Amendments. Except as in the Declaration provided otherwise, these By-Laws may be amended in the following manner:
- §12.1 Notice. Notice of the subject matter of a proposed amendment shall be included in the notice of a meeting at which a proposed amendment is to be considered.
- §12.2 Adoption. A resolution for the adoption of a proposed amendment may be proposed either by a majority of the Board of Directors or by not less than one-third (1/3) of the voting interests of the Association. Directors and members not present in person or by proxy at the meeting considering the amendment may express their approval in writing, provided that such approval is delivered to the Secretary at or prior to the meeting. The approval must be:
- by not less than a majority of the voting interests of all members of the Association represented at a meeting at which a quorum has been attained and by not less than 66-2/3% of the entire Board of Directors; or
  - by not less than eighty (80%) percent of the voting interests of the members of the Association represented at a meeting at which a quorum has been attained; or
  - by not less than one hundred (100%) percent of the entire Board of Directors.
- §12.3 Proviso. No amendment may be adopted which would eliminate, modify, prejudice, abridge or otherwise adversely affect any rights, benefits, privileges or priorities granted or reserved to the Developer or mortgagees of the Units without the consent of said Developer and mortgagees in each instance. No amendment shall be made that is in compliance with the Articles or Declaration.
- §12.4 Execution and Recording. A copy of each amendment shall be attached to a Certificate certifying that the amendment was duly adopted as an amendment of the Declaration and By-Laws, which certificate shall be executed by the President or Vice President and attested by the Secretary or Assistant Secretary of the Association with the formalities of a deed, or by the Developer alone if the amendment has been adopted consistent with the provisions of the Declaration allowing such action by the Developer. The amendment shall be effective when the Certificate and a copy of the amendment is recorded in the Public Records of the County; provided, however, no amendment to these By-Laws shall be valid unless the inner page of the amendment to be recorded shows the book and page of the public records where the Declaration is recorded.
- §12.5 Procedure. The By-Laws shall not be revised or amended by reference to its title or number only. Proposals to amend the By-Laws shall contain the full text of the By-Laws to be amended; new words shall be inserted in the text underlined and words to be deleted shall be lined through with hyphens. However, if the proposed change is so extensive that this procedure would hinder rather than assist the understanding of the proposed amendment, underlining and hyphens as indicative of words added or deleted shall not be used, but instead a notation shall be inserted immediately preceding the proposed amendment in substantially the following language: "Substantial rewording of By Law. See by law.....for present text." Nonmaterial errors or omissions in the by law process shall not invalidate an otherwise properly promulgated amendment.



REC-14302PG 512

13. Rules and Regulations. Annexed hereto as Schedule A and made a part hereof are rules and regulations concerning the use of portions of the Condominium. The Board of Directors may, from time to time, modify, amend or add to such rules and regulations, except that subsequent to the date control of the Board is turned over by the Developer to Unit Owners other than the Developer, Owners of a majority of the voting interests of the Units represented at a meeting at which a quorum is present may overrule the Board with respect to any such modifications, amendments or additions. Copies of such modified, amended or additional rules and regulations shall be furnished by the Board of Directors to each affected Unit Owner not less than thirty (30) days prior to the effective date thereof. At no time may any rule or regulation be adopted which would prejudice the rights reserved to the Developer.
14. Construction. Wherever the context so permits, the singular shall include the plural, the plural shall include the singular, and the use of any gender shall be deemed to include all genders.
15. Captions. The captions herein are inserted only as a matter of convenience and for reference and in no way define or limit the scope of these By-Laws of the intent of any provision hereof.

The foregoing was adopted as the By-Laws of the Association on the \_\_\_\_\_ day of August, 1989.

APPROVED:

  
\_\_\_\_\_  
ROBERT C. SIMONY, President

REC: 17755163965

97R374649 1997 AUG 19 08:18

**CERTIFICATE OF PROMULGATION OF  
COSTAL DEL SOL ASSOCIATION, INC.'S  
REVISED RULES AND REGULATIONS**

**WHEREAS, COSTAL DEL SOL ASSOCIATION, INC., (hereinafter referred to as "ASSOCIATION") is the entity responsible for the operation and administration of the Costa del Sol Condominium A, a Condominium, as described in the Declaration of Condominium thereof, as recorded in Official Records Book 11093 at Page 646 of the Public Records of Dade County, Florida; and**

**WHEREAS, ASSOCIATION is the entity responsible for the operation and administration of the Costa del Sol Condominium B, a Condominium, as described in the Declaration of Condominium thereof, as recorded in Official Records Book 11284 at Page 1080 of the Public Records of Dade County, Florida; and**

**WHEREAS, ASSOCIATION is the entity responsible for the operation and administration of the Costa del Sol Condominium C, a Condominium, as described in the Declaration of Condominium thereof, as recorded in Official Records Book 12417 at Page 2449 of the Public Records of Dade County, Florida; and**

**WHEREAS, ASSOCIATION is the entity responsible for the operation and administration of the Costa del Sol Condominium D, a Condominium, as described in the Declaration of Condominium thereof, as recorded in Official Records Book 14431 at Page 2083 of the Public Records of Dade County, Florida; and**

**WHEREAS, ASSOCIATION is the entity responsible for the operation and administration of the Costa del Sol Condominium E, a Condominium, as described in the Declaration of Condominium thereof, as recorded in Official Records Book 12241 at Page 1193 of the Public Records of Dade County, Florida; and**

**WHEREAS, ASSOCIATION is the entity responsible for the operation and administration of the Costa del Sol Condominium F, a Condominium, as described in the Declaration of**

105-

REF: 1775513966  
REC:CERTIFICATE OF PROMULGATION OF COSTA DEL SOL  
ASSOCIATION, INC.'S REVISED RULES AND REGULATIONS

Condominium thereof, as recorded in Official Records Book 12329 at Page 377 of the Public Records of Dade County, Florida; and

**WHEREAS, ASSOCIATION** is the entity responsible for the operation and administration of the Costa del Sol Condominium G, a Condominium, as described in the Declaration of Condominium thereof, as recorded in Official Records Book 13853 at Page 582 of the Public Records of Dade County, Florida; and

**WHEREAS, ASSOCIATION** is the entity responsible for the operation and administration of the Costa del Sol Condominium H, a Condominium, as described in the Declaration of Condominium thereof, as recorded in Official Records Book 13896 at Page 2784 of the Public Records of Dade County, Florida; and

**WHEREAS, ASSOCIATION** is the entity responsible for the operation and administration of the Costa del Sol Condominium I, a Condominium, as described in the Declaration of Condominium thereof, as recorded in Official Records Book 13758 at Page 1678 of the Public Records of Dade County, Florida; and

**WHEREAS, ASSOCIATION** is the entity responsible for the operation and administration of the Costa del Sol Condominium J, a Condominium, as described in the Declaration of Condominium thereof, as recorded in Official Records Book 14158 at Page 1769 of the Public Records of Dade County, Florida; and

**WHEREAS, ASSOCIATION** is the entity responsible for the operation and administration of the Costa del Sol Condominium K, a Condominium, as described in the Declaration of Condominium thereof, as recorded in Official Records Book 11996 at Page 2761 of the Public Records of Dade County, Florida; and

**WHEREAS, ASSOCIATION** is the entity responsible for the operation and administration of the Costa del Sol Condominium L, a Condominium, as described in the Declaration of Condominium thereof, as recorded in Official Records Book 14757 at Page 3130 of the Public Records of Dade County, Florida; and

**WHEREAS, ASSOCIATION** is the entity responsible for the operation and administration of the Costa del Sol Condominium M, a Condominium, as described in the Declaration of

REF: 1775513967

CERTIFICATE OF PROMULGATION OF COSTA DEL SOL  
ASSOCIATION, INC.'S REVISED RULES AND REGULATIONS

Condominium thereof, as recorded in Official Records Book 14658 at Page 2460 of the Public Records of Dade County, Florida; and

**WHEREAS, ASSOCIATION** is the entity responsible for the operation and administration of the Costa del Sol Condominium N, a Condominium, as described in the Declaration of Condominium thereof, as recorded in Official Records Book 12729 at Page 2786 of the Public Records of Dade County, Florida; and

**WHEREAS, ASSOCIATION** is the entity responsible for the operation and administration of the Costa del Sol Condominium O, a Condominium, as described in the Declaration of Condominium thereof, as recorded in Official Records Book 12463 at Page 568 of the Public Records of Dade County, Florida; and

**WHEREAS, ASSOCIATION** is the entity responsible for the operation and administration of the Costa del Sol Condominium P - Phase 1, a Condominium, as described in the Declaration of Condominium thereof, as recorded in Official Records Book 13115 at Page 4262 of the Public Records of Dade County, Florida; and

**WHEREAS, ASSOCIATION** is the entity responsible for the operation and administration of the Costa del Sol Condominium P - Phase 2, a Condominium, as described in the Declaration of Condominium thereof, as recorded in Official Records Book 13156 at Page 1449 of the Public Records of Dade County, Florida; and

**WHEREAS, ASSOCIATION** is the entity responsible for the operation and administration of the Costa del Sol Condominium Q, a Condominium, as described in the Declaration of Condominium thereof, as recorded in Official Records Book 13709 at Page 3110 of the Public Records of Dade County, Florida; and

**WHEREAS, ASSOCIATION** is the entity responsible for the operation and administration of the Costa del Sol Condominium R, a Condominium, as described in the Declaration of Condominium thereof, as recorded in Official Records Book 14078 at Page 1979 of the Public Records of Dade County, Florida; and

**WHEREAS, ASSOCIATION** is the entity responsible for the operation and administration of the Costa del Sol Condominium S, a Condominium, as described in the Declaration of

OFF. REC. 1775563968

CERTIFICATE OF PROMULGATION OF COSTA DEL SOL  
ASSOCIATION, INC.'S REVISED RULES AND REGULATIONS

Condominium thereof, as recorded in Official Records Book 14023 at Page 2994 of the Public Records of Dade County, Florida; and

**WHEREAS, ASSOCIATION** is the entity responsible for the operation and administration of the Costa del Sol Condominium T, a Condominium, as described in the Declaration of Condominium thereof, as recorded in Official Records Book 14302 at Page 443 of the Public Records of Dade County, Florida; and

**WHEREAS, ASSOCIATION** is the entity responsible for the operation and administration of the Costa del Sol Condominium U, a Condominium, as described in the Declaration of Condominium thereof, as recorded in Official Records Book 14606 at Page 2328 of the Public Records of Dade County, Florida; and

**WHEREAS, ASSOCIATION** is the entity responsible for the operation and administration of the Costa del Sol Condominium V, a Condominium, as described in the Declaration of Condominium thereof, as recorded in Official Records Book 14673 at Page 1577 of the Public Records of Dade County, Florida; and

**WHEREAS, ASSOCIATION** is the entity responsible for the operation and administration of the Costa del Sol Condominium W, a Condominium, as described in the Declaration of Condominium thereof, as recorded in Official Records Book 14539 at Page 2419 of the Public Records of Dade County, Florida; and

**WHEREAS, ASSOCIATION** is the entity responsible for the operation and administration of the Costa del Sol Condominium 1, a Condominium, as described in the Declaration of Condominium thereof, as recorded in Official Records Book 8716 at Page 450 of the Public Records of Dade County, Florida; and

**WHEREAS, ASSOCIATION** is the entity responsible for the operation and administration of the Costa del Sol Condominium 2, a Condominium, as described in the Declaration of Condominium thereof, as recorded in Official Records Book 8716 at Page 528 of the Public Records of Dade County, Florida; and

**WHEREAS, ASSOCIATION** is the entity responsible for the operation and administration of the Costa del Sol Condominium 3, a Condominium, as described in the Declaration of

REC: 17755713969

CERTIFICATE OF PROMULGATION OF COSTA DEL SOL ASSOCIATION, INC.'S REVISED RULES AND REGULATIONS

Condominium thereof, as recorded in Official Records Book 8716 at Page 606 of the Public Records of Dade County, Florida; and

WHEREAS, ASSOCIATION is the entity responsible for the operation and administration of the Costa del Sol Condominium 4, a Condominium, as described in the Declaration of Condominium thereof, as recorded in Official Records Book 8716 at Page 684 of the Public Records of Dade County, Florida; and

WHEREAS, ASSOCIATION is the entity responsible for the operation and administration of the Costa del Sol Cluster A Condominium, a Condominium, as described in the Declaration of Condominium thereof, as recorded in Official Records Book 11893 at Page 3231 of the Public Records of Dade County, Florida; and

WHEREAS, pursuant to Article 5(e) of the Association's By-Laws, the Board of Directors is empowered to adopt and amend Rules and Regulations concerning the details of the operation and use of the Condominiums; and

WHEREAS, the Board of Directors, at a duly convened and noticed meeting thereof held on April 22, 1997, voted to promulgate the revised Rules and Regulations attached hereto as Exhibit "A" and incorporated herein by reference.

NOW THEREFORE, it is hereby certified that the revised Rules and Regulations set forth in Exhibit "A" were duly adopted pursuant to the powers and authority vested in the Board of Directors by the Declarations of Condominium and the By-Laws of the Costa del Sol Association, Inc.

IN WITNESS WHEREOF, we have hereunto affixed our hands and the seal of said Association this 7 day of August, 1997.

WITNESSES:

*[Handwritten signatures of witnesses]*

COSTA DEL SOL ASSOCIATION

*[Signature of Eugene A. Beck]*  
President



REC: 1775563970

CERTIFICATE OF PROMULGATION OF COSTA DEL SOL ASSOCIATION, INC.'S REVISED RULES AND REGULATIONS

WITNESSES:

[Signature]  
[Signature]

[Signature]  
Secretary

STATE OF FLORIDA)  
SS:  
COUNTY OF DADE )

BEFORE ME, the undersigned authority, personally appeared EDUARDO  
BOCHAMPS and SUSAN GLASS, respectively  
President and Secretary of COSTA DEL SOL ASSOCIATION, INC., to me well known to be the  
persons described in and who presented \_\_\_\_\_ and  
\_\_\_\_\_ as identification, and who executed the foregoing instrument and  
they acknowledged jointly and severally to and before me that they executed the foregoing  
instrument as such officers of said Association for the purposes expressed therein and the same is  
the free act and deed of said Association.

WITNESS my hand and official seal this 7 day of August  
Roger Todd  
Notary's Name Printed/Typed

[Signature]  
Notary Public, State of Florida  
at Large



My Commission No.:  
My Commission Exp.:

OFFICIAL NOTARY SEAL  
ROGER TODD  
NOTARY PUBLIC STATE OF FLORIDA  
COMMISSION NO. CC553794  
MY COMMISSION EXP. MAY 9, 2000

This Instrument Prepared By:  
EDUARDO MELONS, ESQUIRE  
HYMAN & KAPLAN, P.A.  
2701 Museum Tower  
130 West Flagler Street  
Miami, Florida 33130  
(305) 371-4344

REF: 1775503971

COSTA DEL SOL ASSOCIATION, INC.  
ONE COSTA DEL SOL BOULEVARD, MIAMI, FLORIDA 33178

# RULES AND REGULATIONS

OCTOBER 1995 - APRIL 1997



- The purpose of this document is to detail the rules and regulations adopted by the Board of Directors to manage the Costa del Sol community and to preserve and protect the value of the assets of the community members.
- The Members of the Board of Directors of Costa del Sol Association, Inc. Are the governing agents of the community.
- Community Associations derive their powers and responsibilities as well as their existence from the laws of the state of Florida, the Association's Articles of Incorporation, By-laws, the Declaration of Condominium.
- A copy of these documents will be given to new residents by the Welcoming Committee, prior to occupancy.
- The term "residents" in this document is intended to include all owners and occupants who have been approved by the Association to reside in Costa del Sol.
- Unit owners, whether in residence at Costa del Sol or not, shall be responsible for the conduct of themselves and of their family, tenant(s), guest(s), visitor(s), agent(s) and all of their employees. No unit owner shall permit any such conduct by these persons that will interfere with the safety, rights, comforts and/or conveniences of other residents and shall ensure full compliance by these persons of all rules and regulations of the Association.



REC: 1775513972

2

# RULES AND REGULATIONS ORDER OF PRESENTATION



**1. TRAFFIC CONTROL RULES AND REGULATIONS..... p. 3**

- 1.1 Valid and Current License Plates..... p. 3
- 1.2 Valid and Current Drivers' Licenses..... p. 3
- 1.3 Entrance to the Community..... p. 3
- 1.4 Bar Code Stickers and Windshield Passes..... p. 4
- 1.5 Parking Violations..... p. 5
- 1.6 Towing..... p. 6
- 1.7 Trucks / Vans..... p. 6
- 1.8 Service and Delivery Vehicles..... p. 7
- 1.9 Motorcycles..... p. 7
- 1.10 Emergency Repairs..... p. 7
- 1.11 Packages..... p. 7
- 1.12 Car Covers..... p. 8

**2. LIMITED COMMON AREAS RULES AND REGULATIONS..... p. 8**

- 2.1 General Maintenance..... p. 8
- 2.2 Garages / Carports..... p. 9
- 2.3 Garbage..... p. 9
- 2.4 Pets..... p. 9
- 2.5 Nuisance and Safety Hazards..... p. 10
- 2.6 Soliciting and Posting of Notices..... p. 10
- 2.7 Lakes..... p. 10
- 2.8 Ducks..... p. 11

**3. RECREATIONAL FACILITIES RULES AND REGULATIONS..... p. 11**

- 3.1 General Rules..... p. 11
- 3.2 Swimming Pool..... p. 11
- 3.3 Tennis Courts..... p. 12
- 3.4 Hockey Rink and Basketball Court..... p. 13

**4. CONTRACTOR RULES AND REGULATIONS..... p. 13**

- 4.1 General..... p. 14

**5. SALES / RENTAL RULES AND REGULATIONS..... p. 14**

- 5.1 Welcoming / Screening..... p. 14
- 5.2 Use and Occupancy..... p. 15

**ADDENDUM..... p. 16**

- A. Pit Buils..... p. 16

REC: 1775913973

3

## 1. TRAFFIC CONTROL RULES AND REGULATIONS



**TRAFFIC CONTROL:** All motorized vehicles which are operated on the streets and roadways of Costa del Sol must display a valid and current license plate. Go carts, ATV's, and other recreational vehicles not licensed to drive on city streets are prohibited from operating in Costa Del Sol. The speed limit in Costa del Sol is (23) twenty-three mph. Passing is prohibited. Violations are subject to citation, fine and/or legal action.

1.1. Valid and Current License Plates: Vehicles not displaying a current and valid license plate are subject to towing at the owner's expense.

1.1.1. A car cover, with a proper decal affixed, is an appropriate alternative when storing an unlicensed vehicle.

1.2. Valid and Current Drivers' Licenses: All drivers on the streets of Costa del Sol must be licensed. Parents are responsible for ensuring that their minor children have a valid driver's license if they drive on the streets of Costa del Sol.

1.3. Entrance to the Community: The Association is not a provider of "Security". Each unit owner provides his/her own form and level of security. Main gate service is provided (24) twenty-four hours each and every day. Roving personnel are employed by the Association to assist in the enforcement of these Rules and Regulations.

1.3.1. All visitors must have telephone clearance from the resident they wish to visit or be on the list of regular visitors provided to the Management Office.

1.3.2. All visitors must register at the front entrance and will be given a dated pass for prominent display on the vehicle dashboard (see Bar Code Stickers and Windshield Passes.).

1.3.3. Taxicabs with residents as passengers must be cleared at the main gate. The resident must be recognized by picture ID (i.e. Drivers license) before entrance is granted.

1.3.4. Any taxi cabs called by residents must be recorded at the gate and the specific resident called to confirm the request.

1.3.5. Realtors must get an approved pass to gain entry to the Association property. The hours for Realtor access to the community are 7:30 a. m. through 8:00 p. m. (9:00 p. m. DST).

OFF.  
REC. 1775513974

4

1.4. Bar Code Stickers and Windshield passes: The purpose of the entrance personnel, bar code stickers and windshield passes are to control community access for the safety of our residents, while allowing reasonable access to the patrons of the golf course and its maintenance personnel. Bar code stickers will be issued to residents of Costa del Sol only after presentation of a valid vehicle registration in the name of an authorized resident. Pass arrangements can be made with the Management Office for extended visits or regular housekeepers and/or vendors. The owner must apply in person at the Management office.

1.4.1. Costa del Sol issues three types of passes: If you obtain a pass from the entrance personnel you will be expected to abide by the conditions for which it was issued:

Regular Guest Pass  
Extended Visit Pass  
Golf Course Pass

1.4.2. A Regular Guest Pass is issued for one day. This type of pass will allow entrance to the community and will allow guests' vehicles to be parked in a designated space for twenty-four (24) hours. Guests may obtain this type of pass from the guardhouse.

1.4.3. An Extended Visit Pass is issued for housekeepers or any people that need extended authorization to enter the community on a consistent basis. This pass is good for up to three (3) months and must be requested in writing or in person by the resident, at the Management office.

1.4.4. Those visiting the golf course will be given a Golf Course Pass. A Golf Course Pass is good for one (1) visit to the golf course. Golf course visitors may obtain this pass from the guardhouse.

1.4.5. Any vehicle with a Golf Course Pass is allowed to enter and park within the golf course parking lot only.

1.4.6. Any vehicle with a Golf Course Pass parked on the condominium property will be towed immediately.

1.4.7. Any car driving around the property with a Golf Course Pass will be asked to return to the golf course parking lot or leave the property immediately.

1.4.8. Entry by Bar Code Sticker is a privilege subject to strict observance of the rules and may be denied or revoked.

1.4.9. Bar Code Stickers are available to residents of Costa del Sol. A current driver's license with a Costa del Sol address or other proof of residence is required for purchase of the stickers.

1.4.10. The fee for the Bar Code Sticker is not refundable.

REC: 1775573975

5

1.4.11. Abuse of the Bar Code Sticker privilege is cause to invalidate or revoke your bar code sticker and render it useless. (No refund will be given.)

1.4.12. Any car without a valid bar code sticker issued by Costa del Sol Association, Inc. will have to obtain a guest pass and will be subject to the same terms and conditions described herein.

1.5. Parking Violations: Parking violations can only be issued by appropriate personnel employed by the condominium to perform this task.

1.5.1. No vehicle in a visible state of disrepair, due to broken window(s), missing door(s), missing hood or missing trunk, may be parked in the common area or visible from the common area.

1.5.2. Parking is permitted in marked spaces only. Unit occupants are required to use garage/carport area and/or driveways deep enough to accommodate a vehicle before occupying a guest parking space..



1.5.3. Improperly parked vehicles are subject to towing at the owners expense.

1.5.4. Vehicles may not be parked in common roadways nor on the grass at any time, all wheels must be on the pavement. Vehicles are not permitted to park along the roadways so as to permit fire, fire/rescue, emergency or sanitation vehicles to have access to the full widths of the roadways. Cars that are parked on the grass or in the common roadways will be towed immediately at the owner's expense.

1.5.5. Any car in visible distress should be pushed to a parking place. It will then be verified that the unit owner is taking care of the problem.

1.5.6. Vehicles parked outside a garage/carport must bear a valid and current license plate and Costa del Sol bar code sticker or current guest pass otherwise they will be subject to towing as specified in section (1.6).

1.5.7. Vehicles parked in driveways and or in front of a garage/carport or unit may not extend into the common area in such a way as to cause a hazard.

1.5.8. Storage of vehicles is prohibited in guest spaces for more than 15 days.

1.5.9. Guests are required to park in designated parking areas. When an activity is planned where five or more vehicles are expected, prior arrangements must be made with the Management Office and front gate personnel for additional parking.

OFF. REC. 1775573976

6

1.5.10. Resident owned boats, trailers, trucks, commercial vehicles and cargo vans in Costa del Sol must be parked totally within the confines of a garage/carport area between 6:00 p.m. and 7:30 a.m. Monday through Saturday and all day Sunday and Holidays.

1.5.11. No trucks or commercial vehicles, campers, mobile homes, motor homes, house trailers or trailers of every other description, recreational vehicles, boats or boat trailers or vans shall be permitted to be parked or to be stored at any place on the Association property. This prohibition of parking shall not apply to temporary parking of trucks and commercial vehicles, such as for pick-up, delivery and other temporary commercial services.

1.5.12. Owners who have units with garages/carports that have been converted are not allowed to park a truck or van (as specified in the section entitled "Trucks and Vans", 1.7).

1.5.13. No vehicle with a car cover is allowed to park in any guest parking space or on the street.

1.5.14. Jet skis must be parked in a garage or carport not in a driveway or guest space.

1.6. Towing: All vehicles in violation of the above rules are subject to towing at the owner's expense.

1.6.1. Expired Pass: Cars parked with an expired pass are subject to towing at the owner's expense.

1.6.2. No Valid Bar Code Sticker or Current Pass in Windshield: Vehicles not displaying a valid Costa del Sol bar code sticker or current guest pass are subject to towing at the owner's expense.

1.6.3. Car Alarms: Cars with alarms that sound frequently or for long periods of time are subject to towing at the owner's expense.

1.6.4 Expired Tags: Vehicles with expired tags will not be towed. The unit owner must go through the Violations procedure.



1.7. Trucks/Vans: Florida Statute 316 defines a truck as: "Any motor vehicle designed, used, or maintained primarily for the transportation of property." Statute 320 adds that a truck is a motor vehicle with a net weight of 5,000 pounds or less designed principally for carrying goods other than the personal effects of the passengers. This definition includes cargo vans as trucks but excludes mail, personal pickups.

REF: 1775573977

7

1.7.1. Mini vans and small personal pickups which are not marked with commercial signs or lettering and are not principally for carrying goods other than the personal effects of the passengers are acceptable vehicles and are treated as any other approved personal vehicle. **REMEMBER:** No vehicle in a visible state of disrepair, due to broken window(s), missing door(s), missing hood or missing trunk, may be parked in the common area or visible from the common area.

1.7.2. Residents are not permitted to maintain a truck permanently, as defined above, or any other commercial vehicles in Costa del Sol.

1.7.3. Visitors or guests driving a truck are not allowed to enter Costa del Sol between 6:00 p.m. and 7:30 a.m. Monday through Saturday and all day on Sunday and Holidays.

1.7.4. No delivery or service trucks are permitted in the community until 7:30 a.m.. The exception is service vehicles responding to an after hours emergency request.

1.7.5. Delivery trucks coming to the golf course are not allowed to enter the property prior to 7:30 a.m..

1.7.6. Commercial vehicles are allowed on the property to visit the golf course during golf course operating hours only.

1.7.7. Moving vans or any other moving vehicles will not be admitted without prior clearance from Management. A proper pass must be obtained from the entrance personnel. Moving vans/vehicles must not arrive before 7:30 a.m. and must be loaded/unloaded and off the grounds by 6:00 p.m.. No moving vans/vehicles are permitted on Sundays or Holidays.

1.8. Service And Delivery Vehicles: Residents must be notified before service/delivery vehicles are permitted entrance to the property. Deliveries and service vehicles are permitted on Monday through Saturday between the hours of 7:30 a.m. and 6:00 p.m. Those vehicles/services creating a noise or a general disturbance may not enter until 8:30 a. m. Emergency vehicles, medical , plumbers, locksmiths, electrical and air conditioning repair personnel will be allowed entry at any time for emergency repairs and/or service.

1.9. Motorcycles: Motorcycles must be operated in a manner so as not to be a nuisance. No motorcycle shall be operated on surfaces other, than the roadways.

1.10. Emergency Repairs: No repairs may be made to any vehicle, boat or other equipment or appliances on or visible from limited common property or common property. Only emergency tire repair or jump starts are allowed.

1.11. Packages: The Main Entrance Personnel cannot accept or distribute messages, notes, packages, checks or goods of any description.

REF: 1775513978  
REC:

8

1.12. Car Covers: Car covers are allowed if they are in good condition and bear a car cover decal issued by Costa del Sol Association, Inc. There is a one time fee for this decal. Car covers must be solid subdued shades of gray, blue, shades of brown, black and green and have no writing except for auto logo. Vehicles with a car cover without the proper bar code sticker or temporary pass are subject to rules violation notice and fine.

## 2. LIMITED COMMON AREA RULES AND REGULATIONS

LIMITED COMMON AREAS: Areas such as garages, carports, driveways, patios, lanais and courtyards are limited common areas owned in common by the owners in the condominium, but for the exclusive use of the unit resident(s). These areas are subject to condominium standards and inspections. No alterations or additions may be made to limited common areas without the prior approval of the Architectural Committee.

### 2.1. General Maintenance:

2.1.1. No structure, ramp, etc. of any nature may be erected on common areas, including roadways, at any time.

2.1.2. No outside storage of personal property is permitted except for aesthetically acceptable patio furniture and barbecue equipment which is not visible from the front of the unit.

2.1.3. Lounges, chairs, barbecues, children's toys, portable basketball hoops or furniture shall not remain on the common areas or limited common areas overnight.

2.1.4. Structures for recreational activities or storage, including temporary tents or sheds, are not permitted.

2.1.5. No outside clotheslines or clothes poles shall be erected. Outside drying of clothes, bedding or rags is not permitted.

2.1.6. No outside antennas, satellite dishes or air conditioners are permitted to be installed upon any unit without the prior approval of the Association.

2.1.7. No trees, shrubs or plants shall be planted or removed from the common areas without the prior written approval of the Association.

2.1.8. All activities, barbecues, etc., on the common areas shall be conducted with consideration for neighbors.

2.1.9 Nothing may be stored on the property which will increase insurance rates or obstruct or interfere with the rights of other residents.

REF: 1775513979

9

**2.2. Garage/Carports:** Open garage and carports are limited common property and are within the individual residents jurisdiction subject to the following conditions:

2.2.1. Bedding, clothes or laundry of any type is not permitted to be dried in an open garage/carport area or any public area.

2.2.2. Use of the open garage/carport areas for storage is prohibited.

2.2.3. Exposed work benches are not permitted.

2.2.4. Toys, motorcycles, bicycles, furniture, equipment or any other items that interfere with the parking of a vehicle within the open garage/carport area is prohibited.

**2.3. Garbage:** Collection is scheduled for (2) two days each week, currently Wednesdays and Saturdays.

2.3.1. Recyclable items are collected once a week, currently Wednesdays. Recyclable items shall be placed in approved bins prior to collection.

2.3.2. All refuse intended for collection must be placed in a plastic garbage can with a closeable lid and a plastic garbage bag inside.

2.3.3. Placing refuse in paper, corrugated board or cardboard containers is strictly prohibited.



2.3.4. Garbage cans and recycling bins may be placed out for collection after 8:00 p.m. on the night prior to the regular collection day(s). Empty containers must be brought in by 10:00 p.m. on collection day(s).

2.3.5. The large dumpster located in the Clubhouse area is for residents use when they are going to be out of town and must leave prior to collection day.

**2.4. Pets:** Your pet must not cause a disturbance or create a nuisance.

2.4.1. Barking dogs are considered a nuisance.

2.4.2. Dogs must be kept leashed at all times when on common areas.



OFF. REC. 1775573980



2.4.3. Cats are not permitted to roam loose on the property.

2.4.4. Dogs cannot be kenneled in patio or garage/carport areas and cannot be left tied outside a unit to trees, posts, etc..

2.4.5. Pet owners are responsible for pick-up and disposal of fecal matter caused by their pets.

2.4.6. The Association may require a pet to be immediately and permanently removed from the community as a result of repeated violation of these rules and regulations.

2.4.7. Pit Bulls: The keeping of pit bull dogs on Costa del Sol property is restricted and is covered in Addendum A of this document.

2.5. Nuisances And Safety Hazards: Residents have a right to the quiet enjoyment of their community. Any disruptive noise or disturbance is a nuisance and is therefore prohibited.

2.5.1. Loud music, boisterous partying and shouting is not permitted.

2.5.2. Any sound or noise audible beyond the boundaries of any individual's private dwelling unit is considered a nuisance. This includes any vibrations or reverberations caused by stereos, televisions, musical instruments or any other device.



2.6. Soliciting and Posting of Notices:

2.6.1. No soliciting is allowed within Costa del Sol at any time. Violations of this rule should be reported to the Management Office.

2.6.2. No Posting of notices is allowed unless cleared through the Management Office.

2.7. Lakes:

2.7.1 The lakes are private property and belong to the golf course.

2.7.2. Absolutely no swimming, boating or fishing is allowed in the lakes.

OFF.  
REC. 1775913981

11

**2.8. Ducks:****2.8.1. There is to be absolutely no feeding of the ducks.****2.8.2. If it is determined that ducks are a problem, they will be humanely removed with prior approval of the Board of Directors.****8. RECREATIONAL FACILITIES RULES AND REGULATIONS**

**RECREATIONAL FACILITIES:** The recreation areas are solely for the use of the condominium residents and their invited guests. Children will be the direct responsibility of their parents or legal guardians, including full supervision of them while within the Association property and including full compliance by them of all the rules and regulations of the Association. All children under fourteen (14) years of age must be accompanied by a responsible adult while entering and/or utilizing the recreation areas or other commonly used facilities.

**3.1 General Rules For Recreational Facilities:**

**3.1.1. Those who utilize the pool area, tennis courts, hockey rink and basketball facilities, and playground shall do so at their own risk. No Lifeguard is Provided. The Association shall not be liable for any personal injury loss of life or property damage in any way caused or arising from the use of the recreational facilities.**

**3.1.2. The use of the swimming pool, pool area, tennis courts and other recreational facilities, during permitted hours, shall be in accordance with regulations adopted from time to time by the Board of Directors and posted in the swimming pool area.**

**3.2. Swimming Pool:**

**3.2.1 The pool is for the use of Costa del Sol residents. All guests must be accompanied by a unit resident. A maximum of four (4) guests is permitted per unit at any one time.**

**3.2.2 The pool is open for general use from 8:00 a.m. to 9:00 p.m. during Eastern Standard time and from 8:00 a.m. to 10:00 p.m. during Daylight Savings time.**

**3.2.3 Children under the age of 12 may use the pool only if accompanied by a responsible adult, over the age of 18, who is also a resident of Costa del Sol.**

**3.2.4 Suitable swimming attire should be worn and showers taken before entering the pool.**

OFF.  
REC. 1775513982

12

3.2.5. Food and beverages are only permitted on the pool deck in non-breakable containers. All trash is to be disposed of properly in the trash cans supplied.

3.2.6 Tossing games (ball, Frisbee, etc.), running, roller skating, roller blading, skate boarding or bicycle riding are strictly prohibited on the pool deck.



3.2.7 The use of radios, tape recorders and musical instruments is only permitted at low to moderate levels, not disturbing to other residents using the pool.

3.2.8 No animals are permitted in the pool or pool area.

3.2.9 Rafts or any other inflatables are prohibited in the pool. This does not include water wings.

3.2.10 Swimming is at your own risk. No lifeguard is on duty.

3.2.11 Children in diapers or nude are not allowed in the pool. All children must wear proper swimming attire

### 3.3. Tennis Courts:

3.3.1. The Board of Directors does not endorse any individual as an official Instructor / Professional of Costa del Sol. Any instructor at Costa del Sol must be U.S.P.T.A. certified and adequately insured.

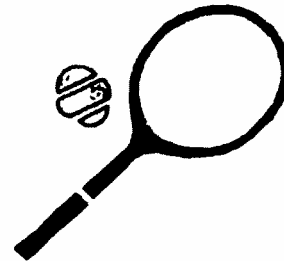

3.3.2. Play is restricted to Costa del Sol residents and their guests.

3.3.3. Courts cannot be booked or reserved in advance, but waiting players must record their time of arrival in order to secure the next available court. Players must also remain present to maintain their place in the waiting list.

3.3.4. If there are waiting players, single play will be limited to one (1) hour and doubles play will be limited to one and a half (1 1/2) hours.

3.3.5. It is the responsibility of those waiting players to notify those players on the court of the expiration of their time.

3.3.6. Courts should be surrendered immediately at the expiration of time, so as not to infringe on the time of other players waiting.

3.3.7. One person will not be permitted to hold a court beyond his/her start time, if his/her opponent has not arrived. The court will be surrendered to the next waiting players. The tardy players may take the position of the advancing players.

OFF: 1775513983  
REC: 1775513983

13

3.3.8. Two (2) or more players of scheduled doubles may not receive a time extension due to the late arrival of the balance of a foursome. If the foursome is not completed within one and a half (1 1/2) hours, the court must be surrendered at that time.

3.3.9. No persons shall be inside the court area unless playing tennis or acting as a referee.

3.3.10. In order to preserve the surface of the courts, players must wear appropriate tennis shoes.

3.3.11. For special events, i.e., tournaments and ladder play, the regular time of play shall be extended to allow players to complete their match.

3.3.12. Tennis courts are to be used only for tennis. No bicycles, skates, skateboards, or other wheeled items are allowed on the court.

3.3.13. Please observe proper tennis etiquette and be courteous and flexible in observance of the above rules.

3.3.14. No food or beverages are ever allowed in the tennis court areas.

3.3.15. Proper tennis attire is required at all times.

3.4. Hockey Rink and Basketball Court:

3.4.1. Play is restricted to Costa del Sol residents and their guests.

3.4.2. The Association assumes no liability for injury, damage or loss of equipment.

3.4.3. Full pads and a helmet are required when utilizing the hockey rink.

3.4.4. There are absolutely no skate boards or skates with metal wheels allowed on the hockey rink.

3.4.5. No pets are allowed on the courts at any time.

#### 4 CONTRACTOR RULES AND REGULATIONS

CONTRACTOR RULES AND REGULATIONS: Contractors must abide by the rules and regulations of the Association.

OFF: 1775513984  
REC:

14

**4.1. General Rules and Regulations for the hiring and use of Contractors:**

4.1.1. The hours that a contractor may be on the Association grounds are 7:30 a. m. to 6:00 p.m., Monday through Saturday, except in an emergency. Emergencies must be cleared by the Office Monday through Friday or the Front Gate on weekends. NO contractors are allowed on the property on Sunday, except in an emergency.

4.1.2. All debris must be hauled away and disposed of off the Association grounds.

4.1.3. All Contractors must be licensed and insured.

**5. SALES/RENTAL RULES AND REGULATIONS**

**SALES / RENTALS RULES AND REGULATIONS:** No sale or lease is permitted without prior written approval of the Association Board of Directors. This approval is obtained by appearing before the Welcoming Committee.

5.1. Welcoming / Screening: Potential lessees and/or purchasers are required to fill out an application for rental or sale and submit that application to the Association Management Office, together with the lease or sale contract and a \$100.00 fee, by at least the Friday prior to the Wednesday scheduled meeting of the Welcoming Committee. The Welcoming Committee meets weekly. However, thirty (30) days notice is required for approval of sales and 10 days notice for approval of leases.

5.1.1 The Association Rules & Regulations do not permit the sale or rental of a unit when there are any outstanding fees or violations against that unit.

5.1.2. Management will advise each condominium representative when a new resident is moving into their cluster. Welcoming Committee meeting notices will be sent to the representatives of the condominiums so that they have an opportunity to attend.

5.1.3. A copy of the current Costa del Sol Rules and Regulations will be provided to prospective residents by Management prior to their scheduled Welcoming Meeting .

5.1.4. No interview will occur unless all the appropriate paper work is submitted by the owner or his/her representative and Management has had the time to make a physical inspection of the unit and also research any violations that may be outstanding.

5.1.5. Renters and new owners must be registered with the Association Management Office in order to be provided free and easy access to the property at the main gate.

OFF. REC. 1775563985

15

5.1.6. New purchasers are required to submit a copy of the warranty deed to the Association office within forty-eight (48) hours of the closing of the sale.

5.2. Use And Occupancy: The Association Management Office must be advised in writing in advance of a proposed loan of a unit. The loan of a unit shall be deemed to be the granting of permission to occupy a unit without payment or consideration, in the absence of the owner of a unit. This section shall not apply to the proposed loan of a unit to a member of the unit owners immediate family (i.e. parents, children, brothers, sisters, grandparents, or grandchildren).

5.2.1. Tenants may not add anyone to the residence list or change occupants of the unit without the prior written consent of the unit owner and the Association. Unilateral changes in the names and/or number of tenants residing in a unit, by tenants or unit owners, is a violation of the lease agreement and will subject the unit owner to fines and/or eviction of all tenants of that unit.

5.2.2. No unit may be leased or loaned more frequently than once in a twelve (12) month period.

5.2.3. All rentals require a minimum of a one (1) year lease.

5.2.4 Use of the homes in Costa del Sol for any purpose other than as a single family residence, by owner, family member, social guest or lessee is not permitted. Units are limited in occupancy by Metropolitan Dade County ordinance and the Association documents. The restrictions are as follows:

Unit size	Maximum occupancy
Two (2) bedroom	Four (4)
Three (3) bedroom	Six (6)



OFF. REC. 1775513986

16

**ADDENDUM A: PIT BULLS**

A. Pit Bulls: The keeping of pit bull dogs on Costa del Sol property is restricted as follows:

A.1. Confinement: Because of the pit bull dog's inbred propensity to attack other animals, and because of the danger posed to humans and animals alike by a pit bull dog when running loose or while running together in a pack, pit bull dogs must at all times be securely confined indoors, or confined in a securely and totally enclosed and locked pen, with either a top or with all four sides at least six (6) feet high, and with a conspicuous sign displaying the words "dangerous dog".

A.1.1. At any time that a pit bull dog is not confined as outlined above, the dog shall be muzzled in such a manner as to prevent it from biting or injuring any person or animal, and kept on a leash with the owner or custodian in attendance. No pit bull may be walked within fifty (50) feet of any public school ground nor enter onto such school ground.

A.1.2. An exception to these confinement requirements is hereby provided for any pit bull dog in attendance at, and participating in any lawful dog show, contest or exhibition sponsored by a dog club, association, society or similar organization.

A.2. Insurance for Pit Bull Owners: In order to protect the public and to afford relief from the severe harm and injury which is likely to result from a pit bull attack, every owner of a pit bull dog shall maintain and be able to provide proof of the owner's financial ability to respond in damages up to and including the amount of three hundred thousand dollars (\$300,000.00) for bodily injury to or death of any person or damage to property which may result from the ownership, keeping or maintenance of such dog. Proof of ability to respond in damages shall be given by filing with the animal control office a certificate of insurance from an insurance company authorized to do business in the state, stating that the owner is and will be insured against liability for such damages; or by posting with the animal control office a surety bond conditioned upon the payment of such damage during the period of such registration; or by posting a personal bond secured by a mortgage in real property or security interest in personal property; or a sworn statement of the owner of his/her financial ability to respond in damages up to and including the amount of three hundred thousand dollars (\$ 300,000.00).

EE:1775573987

17

**A.3. Registration of Pit Bulls:** Every owner of a pit bull dog in metropolitan Dade County shall register the dog with the Animal Services division of the Public Works department of the county. The registration shall include the following: name, address and telephone of the dog's owner, the address where the dog is harbored, if different from the owner's address; a complete identification of the dog including the dog's sex, color and any other distinguishing characteristics; a color photograph of the dog; a description of the method of compliance with the confinement requirements; proof of liability insurance or the evidence of financial responsibility required pursuant to this article; and a registration fee.

**A.4. Proof of Compliance:** The aforementioned requirements must also be submitted to the Costa del Sol Management Office and approved in writing by the Association prior to bringing any pit bull dog on to the Costa del Sol property.

ADMINISTRATIVE RECORDS SECTION  
OF DADE COUNTY, FLORIDA  
RECORDS MANAGER  
HARVEY RUVIN  
CLERK, CIRCUIT COURT

REVISED 04/22/97



OFF. 1430210 513  
REC.

SCHEDULE A TO BY-LAWS  
RULES AND REGULATIONS  
FOR  
COSTA DEL SOL CONDOMINIUM T

1. The sidewalks, entrances, and like portions of the Common Elements shall not be obstructed nor used for any purpose other than for ingress and egress to and from the Condominium Property; nor shall any carts, bicycles, carriages, chairs, tables or any other similar objects be stored therein.
2. The personal property of Unit Owners must be stored in their respective Units or in storage areas.
3. No garbage cans, supplies, milk bottles or other articles shall be placed on the balconies or other Common Elements. No linens, cloths, clothing, curtains, rugs, mops or laundry of any kind, or other articles, shall be shaken or hung from any of the windows, doors, fences, balconies, terraces or other portions of the Condominium Property.
4. No Unit Owner shall permit anything to fall from a window or door of the Condominium Property, nor sweep or throw from the Condominium Property any dirt or other substance into any of the balconies or upon the Common Elements.
5. All refuse must be deposited with all other refuse in areas designated for such purpose by the Developer.
6. Parking areas are solely for non-commercial automobiles with a current passenger vehicle registration.
7. Employees of the Association are not to be sent out by Unit Owners for personal errands. The Board of Directors shall be solely responsible for directing and supervising employees of the Association.
8. No vehicle which cannot operate on its own power shall remain on the Condominium Property for more than twenty-four (24) hours, and no repairs of vehicles shall be made on the Condominium Property.
9. No Unit Owner shall make or permit any disturbing noises in his Unit by himself or his family, servants, employees, agents, visitors or licensees, nor permit any conduct by such persons that will interfere with the peace, comforts or conveniences of other Unit Owners. No Unit Owner shall play or permit to be played any musical instrument, nor operate or permit to be operated a phonograph, television, radio or sound amplifier in his Unit in such a manner as to disturb or annoy other residents. No Unit Owner shall conduct, nor permit to be conducted, vocal or instrumental instruction at any time which disturbs other residents.
10. No radio or television installation may be permitted in any Unit which interferes with the television or radio reception of another Unit.
11. No sign, advertisement, notice or other lettering shall be exhibited, displayed, inscribed, painted or affixed in, on or upon any part of the Condominium Property, except signs used or approved by the Developer. Additionally, no awning, canopy, shutter or other projection shall be attached to or placed upon the outside walls or roof of the Building or on the Common Elements.
12. The Association may retain a pass key to all Units. No Unit Owner shall alter any lock nor install a new lock without the prior written consent of the Board of Directors. Where such consent is given, the Unit Owner shall provide the Association with an additional key.
13. Barbecuing shall be permitted only in designated areas.
14. No flammable, combustible or explosive fluids, chemicals or

REC: 1430270 514

substances shall be kept in any Unit or on the Common Elements, except for use in barbecuing.

15. A Unit Owner who plans to be absent during the hurricane season must prepare his Unit prior to his departure by designating a responsible firm or individual to care for his Unit should the Unit suffer hurricane damage, and furnishing the Association with the name(s) of such firm or individual. Such firm or individual shall be subject to the approval of the Association.

16. Food and beverages may not be consumed outside of a Unit except in designated areas.

17. A Unit Owner shall not cause anything to be affixed or attached to, hung, displayed or place on the exterior walls, doors, balconies or windows of the Building. Curtains and drapes (or linings thereof) which face on exterior windows or glass doors of Units shall be subject to disapproval by the Board, in which case they shall be removed and replaced with acceptable items.

18. No structure of a temporary character, nor trailer, tent, mobile home or recreational vehicle, shall be permitted on the Condominium Property at any time or used on the Condominium Property at any time as a residence either temporarily or permanently. No gas tank, gas container or gas cylinder shall be permitted, except small containers for use in gas barbecues.

19. No oil drilling, oil development operations, oil refining, quarrying or mining operations of any kind shall be permitted, on, upon or in the Condominium Property, nor shall oil wells, tanks, tunnels, mineral excavations or shafts be permitted upon or in the Condominium Property. No derrick or other structure designed for use in boring for oil, natural gas or minerals shall be erected, maintained or permitted upon any portion of the Condominium Property.

20. No trucks or commercial vehicles, campers, mobile homes, motorhomes, house trailers or trailers of every other description, recreational vehicles, boats or boat trailers or vans shall be permitted to be parked or to be stored at any place on the Condominium Property. This prohibition of parking shall not apply to temporary parking of trucks and commercial vehicles, such as for pick-up, delivery and other temporary commercial services, nor to any of the Developer's vehicles.

21. The requirements from time to time of any governmental agency for disposal or collection shall be complied with. All equipment for the storage or disposal of such material shall be kept in a clean and sanitary condition.

22. No air-conditioning units may be installed by Unit Owners. No Unit shall have any aluminum foil placed in any window or glass door or any reflective substance placed on any glass.

23. No exterior antennae shall be permitted on the Condominium Property or Improvements thereon provided that Developer shall have the right to own, install and maintain community antennae and radio and television lines and other temporary communications systems.

24. No chain link fences shall be permitted on the Condominium Property or any portion thereof, except during construction by Developer.

25. Children will be the direct responsibility of their parents or legal guardians, including full supervision of them while within the Condominium Property and including full compliance by them of these restrictions and all the rules and regulations of the Association. All children under fourteen (14) years of age must be accompanied by a responsible adult when entering and or utilizing the recreation areas or other commonly used facilities.

26. No animals or pets of any kind, except as may otherwise be provided in the Declaration shall be kept in any Unit.

27. No Unit Owner shall install a screen enclosure to or upon the outside walls of the Building or on the Common Elements or Limited Common Elements without the prior consent of the Board of Directors.

OFF. REC. 14302PG 515

28. Every Owner and occupant shall comply with these Rules and Regulations as set forth herein, and any and all rules and regulations which from time to time may be adopted, and the provisions of the Declaration and By-Laws as amended from time to time. Failure of an Owner or occupant, licensee or invitee to so comply shall be grounds for action which may include, without limitation, an action to recover sums due for damages, injunctive relief, or any combination thereof. The Association shall have the right to suspend the use of the recreation facilities, if applicable, in the event of failure to so comply. In addition to all other remedies, in the sole discretion of the Board of Directors of the Association, a fine or fines may be imposed upon an Owner for failure of an Owner, his family, guests, licensees, invitees or employees, to comply with any covenant, restriction, rule or regulation herein or in the Declaration, or By-Laws, provided the following procedures are adhered to:

- (a) Notice: The Association shall notify the Owner or occupant and if applicable, his licensee or invitee of the infraction or infractions. Included in the notice shall be a date and time of the next Board of Directors meeting at which time the Owner or occupant shall present reasons why penalties should not be imposed. At such meeting, the Owner or occupant shall be entitled to be represented by counsel (at his expense) and cross-examine and present witnesses and other testimony or evidence.
- (b) Hearing: The non-compliance shall be presented to the Board of Directors after which the Board of Directors shall hear reasons why penalties should not be imposed. Formal rules of evidence shall not apply. A written decision of the Board of Directors shall be submitted to the Owner or occupant by not later than twenty-one (21) days after the Board of Directors' meeting.
- (c) Penalties: The Board of Directors may impose a fine not in excess of Fifty Dollars (\$50.00) for each non-compliance or each violation.
- (d) Payment of Penalties: Fines shall be paid not later than thirty (30) days after notice of the imposition or levy of the penalties.
- (e) Collection of Fines: No fine shall become a lien against a Unit. However, the Board may take such other affirmative and appropriate action as may be necessary to effect collection of fines.
- (f) Application of Penalties: All monies received from fines shall be allocated as directed by the Board of Directors.
- (g) Non-Exclusive Remedy: These fines shall not be construed to be exclusive and shall exist in addition to all other rights and remedies to which the Association may be otherwise legally entitled; however, any penalty paid by the offending Owner shall be deducted from or offset against any damages which the Association may otherwise be entitled to recover by law from such Owner.

29. These Rules and Regulations shall not apply to the Developer, nor its agents or employees and contractors, or to Institutional First Mortgagees, nor to the Units owned by either the Developer or such Mortgagees. All of these Rules and Regulations shall apply, however, to all other Unit Owners and occupants, and, if applicable, their licensees or invitees even if not specifically so stated in portions hereof. The Board of Directors shall be permitted (but not required) to grant relief to one or more Unit Owners from specific Rules and Regulations upon written request therefor and good cause shown in the sole opinion of the Board.

RECORD WITH  
 FOR CONDO MINIMUM PLANS SEE OFFICIAL  
 RECORDS CONDOMINIUM PLANS BK. 229 PAGE 9

RICHARD P. BRINKER, CLERK  
 CIRCUIT & COUNTY COURT

BY [Signature] D. Q.

RECORDED IN OFFICIAL RECORDS BOOK  
 OF CIRCUIT COURT, PALM BEACH  
 COUNTY, FLORIDA  
 RICHARD P. BRINKER  
 CLERK (CIRCUIT COURT)

OFF: 1627410547  
REC:

94R113106 1994 MAR 08 15:17

CERTIFICATE OF AMENDMENT  
TO  
ARTICLES OF INCORPORATION  
OF  
COSTA DEL SOL ASSOCIATION, INC.

WHEREAS, the Certificate of Incorporation of COSTA DEL SOL ASSOCIATION, INC. (hereinafter the "Association") was issued by the Secretary of State of Florida on the 3rd day of April, 1974; and

WHEREAS, at a duly called and convened meeting of the Board of Directors held on January 25, 1994, the amendment to the Articles of Incorporation as set out in Exhibit "A" hereto were adopted by the Board in accordance with the pertinent requirements of the Articles of Incorporation; and

NOW, THEREFORE, the undersigned hereby certifies that the amendment as set forth in Exhibits "A" attached hereto and incorporated herein are a true and correct copy of the amendment as adopted by the Board of Directors as set forth above.

WITNESS my signature hereto this 17th day of February, 1994 at Miami, Florida.

COSTA DEL SOL ASSOCIATION, INC.

Josephine Medina  
Witness

BY: Betty Lambert, President  
(Seal)

James McKeown  
Witness

ATTEST: Thomas W. Bergen, Secretary

STATE OF FLORIDA

COUNTY OF DADE

The foregoing instrument was acknowledged before me this 17th day of February, 1994 by Betty Lambert, the SECRETARY of COSTA DEL SOL ASSOCIATION, INC. a Florida not-for-profit corporation, on behalf of the corporation. Who is personally known to me or has produced ( ) as identification and who did/did not take an oath.

(SEAL)  
NOTARY PUBLIC SIGNATURE  
STATE OF FLORIDA AT  
L. C. SANCHEZ  
MY COMMISSION # 0028901  
EXPIRES: June 16, 1997  
Florida Notary Public Under Seal

My commission expires:

L. C. Sanchez  
PLEASE PRINT OR TYPE NOTARY SIGNATURE

THIS INSTRUMENT PREPARED BY:  
ANTHONY A KALLICHE, ESQUIRE  
BECKER & POLIAKOFF, P.A.  
BLUE LAGOON CORPORATE CENTER  
6161 BLUE LAGOON DRIVE, SUITE 250  
MIAMI, FLORIDA 33128

OFF: 16274PG0548  
REC:AMENDMENT  
TO  
THE  
ARTICLES OF INCORPORATION  
OF  
COSTA DEL SOL ASSOCIATION, INC.

(Additions shown by underlining; deletions shown by "----")

Amendment to Article VIII of the Articles of Incorporation as follows:

ARTICLE VIIIDIRECTORS

The business affairs of this Corporation shall be managed by the Board of Directors, ~~who need not be members nor residents of property within Costa Del Sol~~ each of whom shall be an owner of a unit within Costa Del Sol. The designated voting representative of a unit owned by a corporation, partnership, trust or other similar entity shall be deemed to be the "unit owner" for this purpose of qualifying to serve as a director. At any time a director does not own a unit within Costa Del Sol, he or she shall be deemed to have resigned his or her position on the board. The Corporation shall have three (3) directors initially. The number of directors may be increased from time to time by the By-Laws, but shall never be less than three (3).

Members of the Board of Directors shall be elected and hold office in accordance with the By-Laws of this Corporation.

~~The names and addresses of the persons who are to serve served as the initial directors for the coming year of the corporation, or until the first annual meeting of the corporation are were:~~

William J. Landa	12550 Biscayne Boulevard Miami, Florida 33161
Robert Bookbinder	9701 Costa Del Sol Blvd. Miami, Florida 33166
Walter Turken	12550 Biscayne Boulevard Miami, Florida 33161

OFF: 16274PR0549  
 REC:

EXHIBIT "A"

	Official Records <u>Book</u>	Page
Costa Del Sol Condominium A	11093	646
Costa Del Sol Condominium B	11284	1080
Costa Del Sol Condominium C	12417	2449
Costa Del Sol Condominium D	14431	2083
Costa Del Sol Condominium E	12241	1193
Costa Del Sol Condominium F	12329	377
Costa Del Sol Condominium G	13853	582
Costa Del Sol Condominium H	13896	2784
Costa Del Sol Condominium I	13758	1678
Costa Del Sol Condominium J	14158	1769
Costa Del Sol Condominium K	11996	2761
Costa Del Sol Condominium L	14757	3130
Costa Del Sol Condominium M	14658	2460
Costa Del Sol Condominium N	12729	2786
Costa Del Sol Condominium O	12463	568
Costa Del Sol Condominium P	13115	4262
Costa Del Sol Condominium Q	13709	3110
Costa Del Sol Condominium R	14078	1979
Costa Del Sol Condominium S	14023	2994
Costa Del Sol Condominium T	14302	443
Costa Del Sol Condominium U	14606	2328
Costa Del Sol Condominium V	14673	1577
Costa Del Sol Condominium W	14539	2419
Costa Del Sol Condominium 1	8716	450
Costa Del Sol Condominium 2	8716	528
Costa Del Sol Condominium 3	8716	606
Costa Del Sol Condominium 4	8716	684
Costa Del Sol Cluster A Condominium	11893	323

RECORDED IN OFFICIAL RECORD BOOK  
 OF DADE COUNTY, FLORIDA.  
 RECORD VERIFIED  
 HARVEY RIJVIN,  
 Clerk of Circuit & County  
 Courts

SEE: 1430276 486

# State of Florida



Department of State

I certify from the records of this office that COSTA DEL SOL CONDOMINIUM T ASSOCIATION, INC. is a corporation organized under the laws of the State of Florida, filed on August 24, 1989.

The document number of this corporation is N33863.

I further certify that said corporation has paid all fees due this office through December 31, 1989, and its status is active.

Given under my hand and the Great Seal of the State of Florida, at Tallahassee, the Capital, this the 24th day of August 1989.



CR28022 (8-88)

Jim Smith  
Secretary of State

REC: 14302PG 487

FILED

ARTICLES OF INCORPORATION

REC AUG 24 AM 9 48

FOR

SECRETARY OF STATE  
TALLAHASSEE, FLORIDA

COSTA DEL SOL CONDOMINIUM T ASSOCIATION, INC.

The undersigned, for the purpose of forming a corporation not for profit pursuant to the laws of the State of Florida, does hereby adopt the following articles of incorporation:

ARTICLE I

NAME

The name of the corporation shall be Costa del Sol Condominium T Association, Inc. For convenience, the corporation shall be referred to in this instrument as the "Association", these Articles of Incorporation as the "Articles" and the By-Laws of the Association as the "By-Laws".

ARTICLE II

PURPOSE

The purpose for which the Association is organized is to provide an entity pursuant to the Florida Condominium Act (the "Act") for the operation of that certain condominium located in Dade County, Florida, and known as Costa del Sol Condominium T (the "Condominium").

ARTICLE III

DEFINITIONS

The terms used in these Articles shall have the same definitions and meaning as those set forth in the Declaration of Condominium to be recorded in the Public Records of Dade County, Florida, unless herein provided to the contrary, or unless the context otherwise requires.

ARTICLE IV

POWERS

The powers of the Association shall include and be governed by the following:

- 4.1 General. The Association shall have all of the common law and statutory powers of a corporation not for profit under the laws of Florida that are not in conflict with the provisions of these Articles, the Declaration, the By-Laws or the Act.
- 4.2 Enumeration: The Association shall have all of the powers and duties set forth in the Act except as limited by these Articles, the By-Laws and the Declaration, and all of the powers and duties reasonably necessary to operate the Condominium pursuant to the Declaration and as more particularly described in the By-Laws, as they may be amended from time to time, including, but not limited to, the following:
  - (a) To make and collect Assessments, Special Assessments and other charges against members as Unit Owners, and to use the proceeds thereof in the exercise of its powers and duties.
  - (b) To buy, own, operate, lease, sell, trade and mortgage both real and personal property as may be necessary or convenient in the administration of the Condominium.
  - (c) To maintain, repair, replace, reconstruct, add to and operate the Condominium Property, and other property acquired or leased by the Association for use by Unit Owners.



REF: 143C2PG 488

- (d) To purchase insurance upon the Condominium Property and insurance for the protection of the Association, its officers, directors and members as Unit Owners.
- (e) To make and amend reasonable rules and regulations for the maintenance, conservation and use of the Condominium Property and for the health, comfort, safety and welfare of the Unit Owners.
- (f) To approve or disapprove the leasing, transfer, mortgaging, ownership and possession of Units as may be provided by the Declaration.
- (g) To enforce by legal means the provisions of the Act, the Declaration, these Articles, the By-Laws, and the Rules and Regulations for the use of the Condominium Property.
- (h) To contract for the management and maintenance of the Condominium Property and to authorize a management agent (which may be an affiliate of the Developer) to assist the Association in carrying out its powers and duties by performing such functions as the submission of proposals, collection of Assessments, preparation of records, enforcement of rules and maintenance, repair and replacement of the Common Elements with funds as shall be made available by the Association for such purposes. The Association and its officers shall, however, retain at all times the powers and duties granted by the Condominium Documents, and the Act, including but not limited to the making of Assessments, Special Assessments, promulgations of rules and execution of contracts on behalf of the Association.
- (i) To employ personnel to perform the services required for the proper operation of the Condominium.

- 4.3 Condominium Property. All funds and the titles of all properties acquired by the Association and their proceeds shall be held for the benefit and use of the members in accordance with the provisions of the Declaration, these Articles and the By-Laws.
- 4.4 Distribution of Income; Dissolution. The Association shall make no distribution of income to its members, directors or officers. Upon dissolution all assets of the Association shall be transferred to another corporation not for profit or a public agency.
- 4.5 Limitations. The powers of the Association shall be subject to and shall be exercised in accordance with the provisions hereof and of the Declaration, the By-Laws and the Act.

## ARTICLE V

MEMBERS

- 5.1 Membership: The members of the Association shall consist of all of the record owners of Units in the Condominium from time to time, and after termination of the Condominium shall also consist of those who were members at the time of such termination, and their successors and assigns.
- 5.2 Assignment: The share of a member in the funds and assets of the Association cannot be assigned, hypothecated or transferred in any manner except as an appurtenance to the Unit for which that share is held.
- 5.3 Voting: On all matters upon which the membership shall be entitled to vote, there shall be only one (1) vote for each Unit, which vote shall be exercised or cast in the manner provided by the Declaration and By-Laws. Any person or entity

REC: 14302PG 489

owning more than one Unit shall be entitled to one (1) vote for each Unit owned.

- 5.4 Meetings: The By-Laws shall provide for an annual meeting of members, and may make provision for regular and special meetings of members other than the annual meeting.

ARTICLE VI

TERM OF EXISTENCE

The Association shall have perpetual existence.

ARTICLE VII

INCORPORATOR

The name and address of the incorporator is Morris J. Watsky, 700 N.W. 107th Avenue, Miami, Florida, 33172.

ARTICLE VIII

OFFICERS

The affairs of the Association shall be administered by the officers holding the offices designated in the By-Laws. The officers shall be elected by the Board of Directors of the Association at its first meeting following the annual meeting of the members of the Association and shall serve at the pleasure of the Board of Directors. The By-Laws may provide for the removal from office of officers, for filling vacancies and for the duties of the officers. The names and addresses of the officers who shall serve until their successors are designated by the Board of Directors are as follows:

PRESIDENT:	ROBERT C. SIMON 700 N.W. 107th Avenue Miami, Florida 33172
VICE PRESIDENT:	JAMES WATTS 700 N.W. 107th Avenue Miami, Florida 33172
SECRETARY/TREASURER:	DENISE JOHNSON 70 N.W. 107th Avenue Miami, Florida 33172

ARTICLE IX

DIRECTORS

- 9.1 Number and Qualification. The property, business and affairs of the Association shall be managed by a Board consisting of the number of directors determined in the manner provided by the By-Laws but which shall consist of not less than three (3) directors. Directors need not be members of the Association or residents of Units in the Condominium.
- 9.2 Duties and Powers. All of the duties and powers of the Association existing under the Act, the Declaration, these Articles and the By-Laws shall be exercised exclusively by the Board of Directors, its agents, contractors or employees, subject only to approval by Unit Owners when such approval is specifically required.

OFF: 14302PG 490  
REC:

- 9.3 Election; Removal. Directors of the Association shall be elected at the annual meeting of the members in the manner determined by and subject to the qualifications set forth in the By-Laws. Directors may be removed and vacancies on the Board of Directors shall be filled in the manner provided by the By-Laws.
- 9.4 Term of Developer's Directors: The Developer of the Condominium shall appoint the members of the first Board of Directors and their replacements who shall hold office for the periods described in the By-Laws.
- 9.5 First Directors. The names and addresses of the members of the first Board of Directors who shall hold office until their successors are elected and have qualified, as provided in the By-Laws, are as follows:

<u>NAME</u>	<u>ADDRESS</u>
ROBERT C. SIMONY	730 N.W. 107th Avenue Miami, Florida 33172
JAMES WATTS	730 N.W. 107th Avenue Miami, Florida 33172
DENISE GUTHRIE	730 N.W. 107th Avenue Miami, Florida 33172

## ARTICLE X

INDEMNIFICATION

- 10.1 Indemnity. The Association shall indemnify any person who was or is a party or is threatened to be made a party to any threatened, pending or contemplated action suit or proceeding, whether civil, criminal, administrative or investigative, by reason of the fact that he is or was a Director, officer, employee, officer or agent of the Association, against expenses including attorneys' fees and appellate attorneys' fees, judgments, fines and amounts paid in settlement actually and reasonably incurred by him in connection with such action, suit or proceeding, if he acted in good faith and in a manner he reasonably believed to be in or not opposed to the best interest of the Association, and, with respect to any criminal action or proceeding, had no reasonable cause to believe his conduct was unlawful, except that no indemnification shall be made in respect of any claim, issue or matter as to which such person shall have been adjudged to be liable for gross negligence or malfeasance or willfulness in the performance of his duty to the Association, unless and only to the extent that the court in which such action or suit was brought shall determine upon application that despite the adjudication of liability, but in view of all of the circumstances of the case, such person is fairly and reasonably entitled to indemnity for such expenses which such court shall deem proper. The termination of any action, suit or proceeding by judgment, order, settlement, conviction or upon a plea of nolo contendere or its equivalent shall not, of itself, create a presumption that the person did not act in good faith and in a manner which he reasonably believed to be in or not opposed to the best interest of the Association, and with respect to any criminal action or proceeding, had reasonable cause to believe that his conduct was unlawful.
- 10.2 Expenses. To the extent that a Director, officer, employee or agent of the Association has been successful on the merits or otherwise in defense of any action, suit or proceeding referred to in Section 10.1 above, or in defense of any claim, issue or matter therein, he shall be indemnified against expenses (including attorneys' fees and appellate attorneys' fees) actually and reasonably incurred by him in connection therewith.

REF: 143C2PG 491

10.3 Approval. Any indemnification under Section 10.1 above (unless ordered by a court) shall be made by the Association only as authorized in the specific case upon a determination that indemnification of the Director, officer, employee or agent is proper under the circumstances because he has met the applicable standard of conduct set forth in Section 10.1 above. Such determination shall be made (a) by the Board of Directors by a majority vote of a quorum consisting of directors who were not parties to such action, suit or proceeding, or (b) if such quorum is not obtainable, or, even if obtainable, if a quorum of disinterested Directors so directs, by independent legal counsel in a written opinion, or by a majority of the voting interests of the members.

10.4 Advances. Expenses incurred in defending a civil or criminal action, suit or proceeding may be paid by the Association in advance of the final disposition of such action, suit or proceeding as authorized by the Board of Directors in any specific case upon receipt of an undertaking by or on behalf of the affected Director, officer, employee or agent to repay such amount unless it shall ultimately be determined that he is entitled to be indemnified by the Association as authorized in this Section 10.

10.5 Miscellaneous: The indemnification provided by this Article shall not be deemed exclusive of any other rights to which those seeking indemnification may be entitled under any By-Law, agreement, vote of members or otherwise, and shall continue as to a person who has ceased to be a Director, officer, employee or agent and shall inure to the benefit of the heirs and personal representatives of such person.

10.6 Insurance: The Association shall have the power to purchase and maintain insurance on behalf of any person who is or was a Director, officer, employee or agent of another corporation, partnership, joint venture, trust or other enterprise, against any liability asserted against him and incurred by him in any such capacity, or arising out of his status as such, whether or not the Association would have the power to indemnify him against such liability under the provisions of this Section.

ARTICLE XI

BY-LAWS

The first By-Laws of the Association shall be adopted by the Board of Directors and may be altered, amended or rescinded by the Directors, members and the Developer in the manner provided in the by-laws and the Declaration.

ARTICLE XII

AMENDMENTS

Amendments to these Articles shall be proposed and adopted in the following manner:

12.1 Notice. Notice of the subject matter of a proposed amendment shall be included in the notice of any meeting at which the proposed amendment is to be considered.

12.2 Adoption. A resolution for the adoption of a proposed amendment may be proposed either by a majority of the Board of Directors or by not less than one-third (1/3) of the voting interests of the members of the Association. Directors and members not present in person or by proxy at the meeting considering the amendment may express their approval in writing, providing the approval is delivered to the Secretary at or prior to the meeting. The approvals must be:

REC: 1430296 492

- (a) by not less than a majority of the voting interests of all of the members of the Association represented at a meeting at which a quorum thereof has been attained and by not less than 66-2/3% of the entire Board of Directors; or
- (b) by not less than 80% of the voting interests of all of the members of the Association represented at a meeting at which a quorum has been attained; or
- (c) by not less than 100% of the entire Board of Directors.

12.3 Limitation. Provided, however, that no amendment shall make any changes in the qualifications of membership nor in the voting rights or property rights of members, nor any changes in Section 4.3 and 4.5 of Article 4, entitled "Powers", without the approval in writing of all members and the joinder of all record owners of mortgages upon Units. No amendment shall be made that is in conflict with the Act, the Declaration or the By-Laws, nor shall any amendment make any changes which would in any way affect any of the rights, privileges, powers or options herein provided in favor of or reserved to the Developer, or an affiliate of the Developer, unless the Developer shall join in the execution of the amendment.

12.4 Application to Developer. The Developer may amend these Articles consistent with the provisions of the Declaration allowing certain amendments to be effected by the Developer alone.

12.5 Recording. A copy of each amendment shall be filed with the Secretary of State pursuant to the provisions of applicable Florida law, and a copy certified by the Secretary of State shall be recorded in the Public Records of Dade County, Florida.

ARTICLE XIII

INITIAL REGISTERED OFFICE; ADDRESS AND  
NAME OF REGISTERED AGENT

The initial registered office of the corporation shall be at 700 N.W. 17th Avenue, Miami, Florida 33134, with the privilege of having its office and branch offices at other places within or without the State of Florida. The initial registered agent at that address shall be MORRIS J. WASKY.

IN WITNESS WHEREOF, the undersigned has executed this instrument the 22nd day of August, 1989.

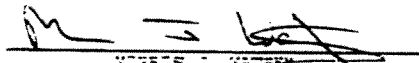
  
MORRIS J. WASKY

ACKNOWLEDGMENT

STATE OF FLORIDA :  
COUNTY OF DADE :

The foregoing instrument was acknowledged before me this 22nd day of August, 1989, by MORRIS J. WASKY.

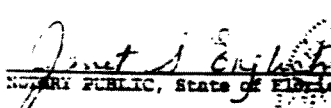
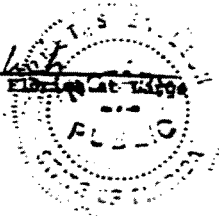
  
JANET S. ENGLISH  
NOTARY PUBLIC, State of Florida  

My Commission Expires:  
NOTARY PUBLIC STATE OF FLORIDA  
MY COMMISSION EXP. AUG. 10, 1992  
BONDED INTO GENERAL ISS. 100

REC: 14302PG 493

FILED

AUG 24 11 9 AM '98

SECRETARY OF STATE  
TALLAHASSEE, FLORIDA

CERTIFICATE DESIGNATING PLACE OF BUSINESS FOR SERVICE OF PROCESS WITHIN THIS STATE, NAMING AGENT UPON WHOM PROCESS MAY BE SERVED.

---

---

Pursuant to Chapter 48.091, Florida Statutes, the following is submitted in compliance with said Act:

That, COSTA DEL SOL CONDOMINIUM T ASSOCIATION, INC., desiring to organize under the laws of the State of Florida, with its principal offices at 700 N.W. 107th Avenue, Miami, Florida 33172, has named MORRIS J. WATSKY, whose office is located at 700 N.W. 107th Avenue, Miami, Florida, as its agent to accept service of process within the State.

ACKNOWLEDGMENT

Having been named to accept service of process for the above stated corporation, at the place designated in this Certificate, I hereby accept to act in this capacity, and agree to comply with the provisions of said Act relative to keeping open said office.

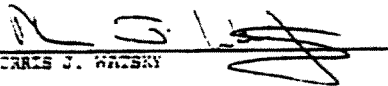
  
MORRIS J. WATSKY

CERTIFICATE OF AMENDMENT TO THE BY-LAWS OF COSTA DEL SOL ASSOCIATION, INC. REC. 1603070295

WHEREAS, the original developer intended to create a muliphase project subject to the control of one association, as evidenced by the Declarations of Condominium for Costa del Sol Condominium No. 1, duly recorded in the Official Records Book of Dade County, O.R. 8716, P. 450; Costa del Sol Condominium No. 2, O.R. 8716, P. 528; Costa del Sol Condominium No. 3, O.R. 8716, P. 607, Costa del Sol Condominium No. 4, O.R. 8716, P. 684, and by the Declaration of Restrictions and Maintenance Covenants for "Costa Del Sol", duly recorded in the Official Records Book of Dade County O.R. 14302, P. 443; and

WHEREAS, the Costa del Sol Association, Inc. is the entity responsible for the operation of all of the condominiums within the Costa del Sol project; and

WHEREAS, the Association is desirous of recording these Amended Bylaws so as to provide constructive notice to those individuals who acquire units in the above referenced condominiums; and

WHEREAS the Amended By-Laws have been approved by the Association in accordance with the applicable provisions of the condominium documents concerning amendment to the By-Laws;

NOW, THEREFORE, the undersigned officers hereby certify that the amended By-Laws set forth in Exhibit "A" attached hereto are a true copy of the By-Laws for Costa del Sol Association, Inc. as approved in accordance with the requirements of the applicable condominium documents.

IN WITNESS WHEREOF, the Costa del Sol Association, Inc. has duly approved and executed the amended By-Laws this 5 day of August, 1993.

[CORPORATE SEAL]



Thomas W. Bergen, Secretary

COSTA DEL SOL ASSOCIATION, INC.

BY: Betty Golub, President

WITNESSES:

[Signature of witness]

STATE OF FLORIDA ) )SS COUNTY OF DADE )

I HEREBY CERTIFY that on this day, before me, an officer duly authorized in the State and County aforesaid to take acknowledgments, personally appeared Betty Golub, President and Thomas W. Bergen, Secretary respectively of the corporation named in the foregoing amendment, and that they severally acknowledged executing the same in the presence of two subscribing witnesses freely and voluntarily under authority duly vested in them by said corporation and that the seal affixed thereto is the true and corporate seal of said corporation.

WITNESS my hand and official seal in the County and State last aforesaid this 5 day of August, 1993.

Deborah S. Allman, Notary Public, State of Florida, At Large, My Commission Number, My Commission Expires, Personally Known



This Instrument Prepared By EDO MELONI, ESQ. HYMAN & KAPLAN, P.A. 44 West Flagler St., 14th Fl. Miami, FL 33130

\\np\costa-b and

93R419093 1993 AUG 24 12:13

Decl For CONDOT (MAY HAVE meant 8716/47)

96.2

OFF.  
REC: 16030M0296

**BY-LAWS OF COSTA DEL SOL ASSOCIATION, INC.**

**A corporation not for profit**  
**under the laws of the State of Florida**

1. **Identity.** These are the By-Laws of Costa del Sol Association, Inc., (the "Association"), a corporation not for profit, incorporated under the laws of the State of Florida for the purpose of administering certain condominiums located in Dade County, Florida, and known as Costa del Sol Condominiums (the "Condominiums").
  - Section 1.1 **Principal Office.** The principal office of the Association shall be One Costa del Sol Boulevard, Miami, Florida, 33172, or at such other place as may be subsequently designated by the Board of Directors.
  - Section 1.2 **Fiscal Year.** The fiscal year of the Association shall be the calendar year.
  - Section 1.3 **Seal.** The seal of the Association shall bear the name of the corporation, the word "Florida", the words "Corporation Not for Profit", and the year of incorporation.
2. **Definitions.** For convenience, the Florida Condominium Act shall be referred to as "Act" these By-Laws shall be referred to as the "By-Laws" and the Articles of Incorporation of the Association as the "Articles". The other terms used in these By-Laws shall have the same definition and meaning as those set forth in the Declarations for the Condominiums, unless herein provided to the contrary, or unless the context otherwise requires.
3. **Members.**
  - Section 3.1 **Annual Meeting.** The annual members' meeting shall be held on the date, at the place and at the time determined by the Board of Directors from time to time, provided that there shall be an annual meeting every calendar year and, to the extent possible, no later than thirteen (13) months after the last preceding annual meeting. The purpose of the meeting shall be, except as provided herein to the contrary, to elect Directors and to transact any other business authorized to be transacted by the members, or as stated in the notice of the meeting sent to Unit Owners in advance thereof.
  - Section 3.2 **Special Meeting.** Special members' meetings shall be held at such places as provided herein for annual meetings, and may be called by the President or by a majority of the Board of Directors of the Association, and must be called by the President or Secretary upon receipt of a written request from a majority of all the voting interests of the membership of the Association. The business conducted at a special meeting shall be limited to that stated in the notice of the meeting. Additionally, special members' meetings may be called by ten (10%) percent of the voting interests of the Unit Owners of the Association to recall a member or members of the Board of Directors or as provided for in Section 9.1(a) (ii) hereof; which meetings shall be called and held in accordance with the terms and provisions of the Act and Section 4.3 hereof.
  - Section 3.3 **Notice of Meeting; Waiver of Notice.** Notice of a



OFF. REC. 16030PC0297

## Exhibit "A" - Page 2

meeting of members stating the time and place and the purpose(s) for which the meeting is called shall be given by the President or Secretary. A copy of the notice shall be posted at a conspicuous place on each of the Condominiums' Property. The notice of the annual meeting shall be sent by mail to each Unit Owner, unless the Unit Owner waives in writing the right to receive notice of the annual meeting by mail. The delivery or mailing shall be to the address of the member as it appears on the roster of members. The posting and mailing of the notice shall be effected not less than fourteen (14) nor more than sixty (60) days prior to the date of the meeting. An officer of the Association shall provide an affidavit, to be included in the official records of the Association, affirming that notice of the Association meeting were mailed or hand delivered in accordance with this provision, to each Unit Owner at the address last furnished to the Association.

Notice of specific meetings may be waived before or after the meeting and the attendance of any member (or person authorized to vote for such member) shall constitute each member's waiver of notice of such meeting, except when his (or his authorized representative's) attendance is for the express purpose of objecting at the beginning of the meeting to the transaction of business because the meeting is not lawfully called.

## Section 3.4

Quorum. A quorum at members' meetings shall be attained by the presence, either in person or by proxy, of persons entitled to cast a majority of the voting interests of the entire membership. If any proposed meeting cannot be organized because a quorum has not been attained, (notwithstanding anything contained herein to the contrary) at such new meeting or meetings (if additional meetings are necessary in order to obtain the reduced quorum as hereinafter provided) the presence either in person or by proxy of persons entitled to cast 33 1/3% of the voting interests of the entire membership shall constitute a quorum at such new meeting or meetings; it being intended that in the event a majority quorum cannot be obtained at any meeting of the members, that the quorum requirements be reduced for the purposes of the new meeting or meetings to which the original meeting is adjourned only. At such new meeting or meetings, if necessary, at which a quorum exists any business may be transacted which might have been transacted at the meeting originally called.

## Section 3.5

Voting.

- (a) Number of Votes. In any meeting of members, the Owners of Units shall be entitled to cast one (1) vote for each Unit owned. The vote of a Unit shall not be divisible.
- (b) Majority Vote. The acts approved by a majority of the voting interests present in person or by proxy at a meeting at which a quorum shall have been attained shall be binding upon all Unit Owners for all purposes except where otherwise provided by law, the

OFF: 16030P0298  
REC: 16030P0298

## Exhibit "A" - Page 3

various Declarations, the Articles or these By-Laws. As used in these By-Laws, the Articles or the Declarations, the terms "majority of the Unit Owners" and "majority of the members" shall mean a majority of the voting interests of Unit Owners and not a majority of members themselves and shall further mean more than fifty (50%) percent of the then total authorized voting interests present in person or by proxy and voting at any meeting of the Unit Owners at which a quorum shall have been attained. Similarly, if some greater percentage of members is required herein or in the various Declarations, or Articles, it shall mean such greater percentage of the voting interests of members and not of the members themselves.

- (c) Voting Member. If a Unit is owned by one person, his right to vote shall be established by the roster of members. If a unit is owned by more than one person, the person entitled to cast the vote for the Unit shall be designated by a certificate signed by all of the record owners of the Unit according to the roster of Unit owners and filed with the Secretary of the Association. Such person need not be a Unit owner, nor one of the joint owners. If a Unit is owned by a corporation, the person entitled to cast the vote for the Unit shall be designated by a Voting Certificate signed by an appropriate officer of the corporation and filed with the Secretary of the Association. Such person need not be a Unit Owner. Those Voting Certificates shall be valid until revoked or until superseded by a subsequent Voting Certificate or until a change in the ownership of the Unit concerned. A Voting Certificate designating the person entitled to cast the vote for a Unit may be revoked if by a record owner of an undivided interest in the Unit. If a Voting Certificate designating the person entitled to cast the vote for Unit for which the Voting Certificate is required is not on file or has been revoked, the vote of the Owner(s) of such Unit shall not be considered in determining whether a quorum is present, nor for any other purpose, and the total number of authorized votes in the Association shall be reduced accordingly until the Voting Certificate is filed, except if the Unit is owned jointly by a husband and wife, they may, without being required to do so, designate a voting member in the manner provided above. Such designee need not be a Unit Owner. In the event a husband and wife do not designate a voting member, the following provisions shall apply:

- (i) If both are present at a meeting and are unable to concur in their decision upon any subject requiring a vote, they shall lose their right to vote on that subject at that meeting, and their vote shall not be considered in determining whether a quorum is present on that subject at the meeting (and the total number of

OFF. REC. 16030P0299

## Exhibit "A" - Page 4

authorized votes in the Association shall be reduced accordingly for such subject only).

- (ii) If only one is present at a meeting, the person present shall be counted for purposes of a quorum and may cast the Unit vote just as though he or she owned the Unit individually, and without establishing the concurrence of the absent person.
- (iii) If both are present at a meeting and concur, either one may cast the Unit vote.

Section 3.6 Proxies. Votes may be cast in person or by proxy. A proxy may be made by any person entitled to vote, but shall only be valid for the specific meeting for which originally given and any lawful adjourned meetings thereof. In no event shall any proxy be valid for a period longer than ninety (90) days after the date of the first meeting for which it was given. Every proxy shall be revocable at any time at the pleasure of the person executing it. A proxy must be in writing, signed by the person authorized to cast the vote for the Unit (as above described), specify the date, time and place of the meeting for which it is given and be filed with the Secretary before the appointed time of the meeting, or before the time to which the meeting is adjourned. Holders of proxies need not be Unit Owners.

Section 3.7 Adjourned Meetings. If any proposed meeting cannot be organized because a quorum has not been attained, the members who are present, either in person or by proxy, may adjourn the meeting from time to time until a reduced quorum as provided in Section 3.4 hereof is present, provided notice of the newly scheduled meeting is given in the manner required for the giving of notice of a meeting. The notice of the newly scheduled meeting shall provide for among other things, that the quorum requirement has been reduced; and that a quorum shall be attained by the presence either in person or by proxy of persons entitled to cast 33 1/3% of the voting interests of the entire membership. Proxies given for the adjourned meeting shall be valid for the newly scheduled meeting unless revoked for reasons other than the new date of the meeting.

Section 3.8 Order of Business. If a quorum has been attained, the order of business at annual members' meetings and, if applicable, at other members' meetings, shall be:

- (a) Call to order by President;
- (b) Appointment by the President of a chairman of the meeting (who need not be a member or a director);
- (c) Proof of notice of the meeting or waiver of notice;
- (d) Reading of minutes;

REF: 16030P0300

## Exhibit "A" - Page 5

- (e) Reports of officers;
- (f) Reports of committees;
- (g) Appointment of inspectors of election;
- (h) Election of Directors;
- (i) Unfinished business;
  
- (j) New business;
- (k) Adjournment.

Such order may be waived in whole or in part by direction of the chairman.

Section 3.9 Minutes of Meeting. The minutes of all meetings of members shall be kept in a book available for inspection by members or their authorized representatives and Board members at any reasonable time. The Association shall retain these minutes for a period of not less than seven (7) years.

Section 3.10 Action Without a Meeting. Anything to the contrary herein notwithstanding, to the extent lawful, any action required to be taken at any annual or special meeting of members, or any action which may be taken at any annual or special meeting of such members shall be taken at a duly noticed meeting of members; except that any action may be taken without a meeting, without prior notice and without a vote if a consent in writing, setting forth the action so taken shall be signed by the members (or persons authorized to cast the vote of any such member as elsewhere herein set forth) having not less than the minimum number of voting interests that would be necessary to attain a quorum, or, with respect to certain matters where a higher percentage of members is required, such number of voting interests that would be necessary to approve such matters. Within ten (10) days after obtaining such authorization by written consent, notice must be given to members who have not consented in writing. The notice shall fairly summarize the material features of the authorized action.

#### 4. Directors.

Section 4.1 Membership. The affairs of the Association shall be governed by a Board consisting of twenty-eight (28) Directors, such number being equal to the total number of Condominiums at Costa del Sol, except as otherwise provided herein from time to time, upon the vote of the majority of the voting interests of the membership.

Section 4.2 Election of Directors. The election of Directors shall be conducted in the following manner:

- (a) Election of Directors shall be held at the annual members' meeting, except as provided herein to the contrary.
- (b) Nominations for Directors may be made by a

OFF. REC. 16030PP0301

## Exhibit "A" - Page 6

nominating committee appointed by the Board of Directors and shall be made from the floor at the election meeting.

- (c) The election shall be by written ballot (unless dispensed with by majority consent of the voting interests of the members represented at the meeting) and by a plurality of the votes cast, each person voting shall be entitled to cast his vote for each of as many nominees for the vacancy to be filled. There shall be no cumulative voting.
- (d) Each condominium shall be entitled to elect one Director as its representative upon the Board. The Director for each Condominium shall be elected by a majority of the votes constituting the membership of the applicable Condominium present at such meeting.

Section 4.3 Vacancies and Removal.

- (a) Except as to vacancies resulting from removal of Directors by members, vacancies in the Board of Directors occurring between annual meetings of members shall be filled by the remaining Directors, provided that all vacancies in directorships shall be filled by an Owner from the Condominium represented by the Director who is to be replaced.
- (b) Subject to the provisions of the Act and of these By-Laws, any member of the Board may be recalled and removed from office with or without cause by the vote or agreement in writing by a majority of all the voting interests. A special meeting of the Unit Owners to recall a member or members of the Board may be called by ten percent (10%) of the voting interests giving notice of the meeting as required for a meeting of Unit Owners, and the notice shall state the purpose of the meeting.
  - (i) If the recall is approved by a majority of all voting interests by a vote at a meeting, the recall shall be effective immediately, and the recalled member or members of the Board shall turn over to the Board any and all records of the Association in his or their possession, within 72 hours after the meeting.
  - (ii) If the proposed recall is by an agreement in writing by a majority of all voting interests, the agreement in writing shall be served on the Association by certified mail. The Board shall call a meeting of the Board within 72 hours after receipt of the agreement in writing and shall either certify the written agreement to recall a member or members of the Board, in which case each member or members shall be recalled effective immediately and shall turn over to the Board within 72 hours, any and all records of the Association in his or their possession, or proceed as described in subparagraph (iii) below.

OFF. REC. 16030P0302

Exhibit "A" - Page 7

- (iii) If the Board determines not to certify the written agreement to recall a member or members of the Board, or if the recall by a vote at a meeting is disputed, the Board shall, within 72 hours, file with the Division of Florida Land Sales, Condominiums and Mobile Homes (the "Division"), a petition for binding arbitration pursuant to the procedures of the Act. For purposes of this Section 4.3(c), the Unit Owners who voted at the

meeting or who executed the agreement in writing shall constitute one party under the petition for arbitration. If the arbitrator certifies the recall as to any member or members of the Board, the recall shall be effective upon service of the final order of arbitration upon the Association. If the Association fails to comply with the order of the arbitrator, the Division may take appropriate action pursuant to the Act. Any member or members so recalled shall deliver to the Board any and all records of the Association in his or their possession within 72 hours of the effective date of the recall.

- (c) If the office of any Director or Directors becomes vacant by reason of death, resignation, retirement, disqualification, removal from office or otherwise, a majority of the remaining Directors, though less than a quorum, shall choose a successor or successors, who shall hold office for the balance of the unexpired term in respect to which such vacancy occurred. The election held for the purpose of filling said vacancy may be held at any regular or special meeting of the Board of Directors. The vacancy filled shall be by a qualified person from the same Condominium which the former Director represented.
- (d) In the event the total number of Directors is less than twenty-eight (28), then the elected Board shall assume its responsibilities as composed.

Section 4.4 Term. Except as provided herein to the contrary, the term of each Director's service shall extend until the next annual meeting of the members and subsequently until his successor is duly elected and qualified, or until he is removed in the manner elsewhere provided.

Section 4.5 Organizational Meeting. The organizational meeting of newly-elected or appointed members of the Board of Directors shall be held within ten (10) days of their election or appointment at such place and

OFF. 16030P0303  
REC.

Exhibit "A" - Page 8

time as shall be fixed by the Directors at the meeting at which they were elected or appointed, and no further notice to the Board of the organizational meeting shall be necessary.

## Section 4.6

Regular Meetings. Regular meetings of the Board of Directors may be held at such time and place as shall be determined, from time to time, by a majority of the Directors. Notice of regular meetings shall be given to each Director, personally or by mail, telephone or telegraph, and shall be transmitted at least three (3) days prior to the meeting. Regular meetings of the Board of Directors shall be open to all Unit Owners and notice of such meetings shall be posted conspicuously on the Condominium Property at least forty-eight (48) hours in advance for the attention of the members of the Association, except in the event of an emergency, provided that Unit Owners shall not be permitted to participate and need not be recognized at any such meeting.

## Section 4.7

Special Meetings. Special meetings of the Directors may be called by the president and must be called by the President or Secretary at the written request of one-third (1/3) of the Directors. Notice of the meeting shall be given personally or by mail, telephone or telegraph, which notice shall state the time, place and purpose of the meeting and shall be transmitted not less than three (3) days prior to the meeting. Special meetings of the Board of Directors shall be open to all Unit Owners and notice of a special meeting shall be posted conspicuously on the Condominium Property at least forty-eight (48) hours in advance for the attention of the members of the Association, except in the event of an emergency, provided that Unit Owners shall not be permitted to participate and need not be recognized at any such meeting.

## Section 4.8

Waiver of Notice. Any Director may waive notice of a meeting before or after the meeting and that waiver shall be deemed equivalent to be due receipt by said Director of notice. Attendance by any Director at a meeting shall constitute a waiver of notice of such meeting, except when his attendance is for the express purpose of objecting at the beginning of the meeting to the transaction of business because the meeting is not lawfully called.

## Section 4.9

Quorum. A quorum at Directors' meetings shall consist of a majority of the entire Board of Directors. The acts approved by a majority of those present at a meeting at which a quorum is present shall constitute the acts of the Board of Directors except when approval by a greater number of Directors is specifically required by the Declarations, the Articles or these By-Laws.

## Section 4.10

Adjourned Meetings. If at any proposed meeting of the Board of Directors there is less than a quorum present, the majority of those present may adjourn the meeting from time to time until a quorum is present, provided notice of such newly scheduled meeting is given as required hereunder. At any newly scheduled meeting, any business that might have been transacted at the meeting as originally called may be transacted without further notice.

OFF. REC. 16030PP0304

Exhibit "A" - Page 9

- Section 4.11 Joinder in Meeting by Approval of Minutes. The joinder of a Director in the action of a meeting by signing and concurring in the minutes of that meeting shall constitute the approval of that Director of the business conducted at the meeting.
- Section 4.12 Presiding Officer. The presiding officer at the Directors' meetings shall be the president (who may, however, designate any other person to preside). In the absence of the presiding officer, the Directors present may designate any person to preside.
- Section 4.13 Order of business. If a quorum has been attained, the order of business at Director's meetings shall be:
- (a) Proof of due notice of meeting;
  - (b) Reading and disposal of any unapproved minutes;
  - (c) Reports of officers and committees;
  - (d) Election of officers;
  - (e) Unfinished business;
  - (f) New business;
  - (g) Adjournment.
- Such order may be waived in whole or in part by direction of the presiding officer.
- Section 4.14 Minutes of Meetings. The minutes of all meetings of the Board of Directors shall be kept in a book available for inspection by Unit Owners, or their authorized representatives, and Board members at any reasonable time. The Association shall retain these minutes for a period of not less than seven (7) years.
- Section 4.15 Action Without a Meeting. Anything to the contrary herein notwithstanding, and to the extent lawful, any action required to be taken at a meeting of the Directors, or any action which may be taken at a meeting of Directors or a committee thereof, may be taken without a meeting if a consent in writing setting forth the action so to be taken signed by all of the Directors of all the members of the committee, as the case may be, is filed in the minutes of the proceedings of the Board or of the committee. Such consent shall have the same effect as a unanimous vote. No prior notice of such intended action shall be required to be given to the Directors or to the Unit Owners. Notice of the taking of such action pursuant hereto shall, however, be posted conspicuously on the Condominium Property for the attention of Owners after such action shall have been effected. Such notice shall fairly summarize the material features of the action so taken.
- Section 4.16 Executive Committee; Other Committees. The Board of Directors may, by resolution duly adopted, appoint an Executive Committee to consist of three (3) or more members of the Board of Directors. Such Executive Committee shall have and may exercise all of the powers of the Board of Directors in management of the business and affairs of the Condominiums during the period between the meetings of the Board of Directors insofar as may



OFF. REC. 16030P0305

Exhibit "A" - Page 10

be permitted by law, except that the Executive Committee shall not have power (a) to determine the Common Expenses required for the affairs of the Condominiums, (b) to determine the Assessments or Special Assessments payable by the Unit Owners to meet the Common Expenses of the Condominiums, (c) to adopt or amend any rules and regulations covering the details of the operation and use of the Condominium Properties, or (d) to exercise any of the powers set forth in paragraph (g) and (p) of Section 5 below.

Section 4.17 Attendance. A Director who is present at any Directors' meeting at which action on any corporate matter is taken shall be presumed to have assented to the action taken, unless he votes against such action or abstains from voting in respect thereto because of an asserted conflict of interest.

5. Powers and Duties. The Board of Directors shall have the powers and duties necessary for the administration of the affairs of the Condominiums and may take all acts, through the proper officers of the Association, in executing such powers, except such acts which by law, the Declarations, the Articles or these By-Laws may not be delegated to the Board of Directors by the Unit Owners. Such powers and duties of the Board of Directors shall include, without limitation (except as limited elsewhere herein) the following:

- (a) Operating and maintaining the Common Elements of each Condominium.
- (b) Determining the expenses required for the operation of the Condominiums and the Association.
- (c) Collecting the Assessments and Special Assessments from Unit Owners.
- (d) Employing and dismissing the personnel necessary for the maintenance and operation of the Common Elements of Each Condominium.
- (e) Adopting and amending rules and regulations concerning the details of the operation and use of the Condominium Properties, subject to a right of the Unit Owners to overrule the Board as provided in Section 13 hereof.
- (f) Maintaining bank accounts on behalf of the Association and designating the signatories required therefor.
- (g) Purchasing, leasing, holding or otherwise acquiring Units or other property in the name of the Association or its designee for the use and benefit of its members.
- (h) Purchasing Units at foreclosure or other judicial sales, in the name of the Association or its designee.
- (i) Selling, leasing, mortgaging or otherwise dealing with Units acquired by, and subleasing Units leased by, the Association or its designee.
- (j) Organizing corporations and appointing persons to act as designees of the Association in acquiring title to or leasing Units or other property.
- (k) Obtaining and maintaining adequate insurance to protect the Association, the Association Property, if any, and the Condominium Properties.
- (l) Making repairs, additions and improvements to, or alterations of, the Condominium Properties, and repairs

OFF. REC. 16030P0306

## Exhibit "A" - Page 11

to and restoration of the Condominium Properties in accordance with the provisions of the Declarations after damage or destruction by fire or other casualty or as a result of condemnation or eminent domain proceedings or otherwise.

- (m) Enforcing obligations of the Unit Owners, allocating profits and expenses and taking such other actions as shall be deemed necessary and proper to the sound management of the Condominiums.
- (n) Levying fines where appropriate against Unit Owners for violations of the rules and regulations established by the Association to govern the conduct of such Unit Owners.
- (o) Purchasing or leasing Units for use by resident superintendents.
- (p) Borrowing money on behalf of the Condominiums when required in connection with the operation, care, upkeep and maintenance of the Common Elements or the acquisition of property, and granting mortgages on and/or security interests in Association Property; provided, however, that the consent of the Owners of at least two-thirds (2/3) of the voting interest of the Units represented at a meeting at which a quorum has been attained in accordance with the provisions of these By-Laws shall be required for the borrowing of any sum in excess of \$20,000.00. If any sum borrowed by the Board of Directors on behalf of the Condominiums pursuant to the authority contained in this subparagraph (p) is not repaid by the Association, a Unit Owner who pays to the creditor such portion thereof as his interest in his Common Elements bears to the interest of all the Unit Owners in the Common Elements shall be entitled to obtain from the creditor a release of any judgment or other lien which said creditor shall have filed or shall have the right to file or which will affect such Unit Owner's Unit.
- (q) Contracting for the management and maintenance of the Condominium Properties and authorizing a management agent (which may be an affiliate of the Developer) to assist the Association in carrying out its powers and duties by performing such functions as the submission of proposals, collection of Assessments, Special Assessments, preparation of records, reenforcement of rules, and maintenance, repair and replacement of the Common Elements with funds as shall be made available by the Association for such purposes. The Association shall, however, retain at all times the powers and duties granted by the Condominium Documents and the Act, including but not limited to the making of Assessments, Special Assessments, promulgation of rules and the execution of contracts on behalf of the Association.
- (r) At its discretion, authorizing Unit Owners or other persons to use portions of the Common Elements or Association Property for private parties and gatherings and imposing reasonable charges for such private use provided such use is the subject of a lease between the Association and the Unit Owner.
- (s) At its discretion, initiating or authorizing voluntary binding arbitration of internal disputes arising from the operation of the Condominiums among Unit Owners, the Association, their agents and assigns in accordance with the rules of procedure promulgated by the Department of Business Regulation.

OFF. REC. 16030PP0307

Exhibit "A" - Page 12

- (t) Imposing a lawful fee in connection with the approval of the transfer, sale, lease, or sublease of Units.
- (u) Subject to the prior consent of the Developer, which consent shall be required until December 31, 1999 or until Developer has conveyed a title to the last Condominium Unit to be built in Costa del Sol Project - Stage 2, or such earlier time, as may be determined in the sole discretion of Developer, to grant, modify or move any easement, subject to the provisions of the easement, without the joinder of any Unit Owners, if the easement constitutes part of or crosses the Common Elements.
- (v) Exercising (i) all powers specifically set forth in the Declarations, the Articles, these By-Laws, and in the Act, and (ii) all powers incidental thereto, and all other powers of a Florida corporation not for profit under Florida Statutes, Chapters 607 and 617, (as they exist on the date hereof and as hereafter renumbered), as applicable, if not inconsistent with the Act.
- (w) Levying Assessments for Common Expenses against Unit Owners for their share of the items in the budget, and/or Special Assessments for Common Expenses for emergencies for the Association.
- (x) Maintaining a copy of each of the following, where applicable, which shall constitute the official records of the Association:
  - (1) The plans, permits, warranties, and other items provided by the Developer;
  - (2) A photocopy of the recorded declaration of each condominium operated by the Association and all amendments thereto;
  - (3) A photocopy of the recorded By-Laws of the Association and all amendments thereto;
  - (4) A certified copy of the Articles of Incorporation of the Association or other documents creating the Association and all amendments thereto;
  - (5) A copy of the current rules of the Association;
  - (6) A book or books containing the minutes of all meetings of the Association, of the Board of Directors, and of Unit Owners, which minutes shall be retained for a period of not less than 7 years;
  - (7) A current roster of all Unit Owners, their mailing addresses, Unit identifications, Voting Certificates, and if known, telephone numbers;
  - (8) All current insurance policies of the Association and Condominiums operated by the Association;
  - (9) A current copy of any management agreement, lease, or other contract to which the Association is a party or under which the Association or the Unit Owners have an obligation or responsibility;
  - (10) Bills of sale or transfer for all property owned by the Association;
  - (11) Accounting records for the Association and separate accounting records for each Condominium it operates, according to good accounting practices. All accounting records shall be maintained for a period of not less than 7 years. The accounting

OFF. REC. 1603000308

## Exhibit "A" - Page 13

records shall include, but are not limited to:

- (a) Accurate, itemized, and detailed records of all receipts and expenditures.
  - (b) A current account and a monthly, bimonthly, or quarterly statement of the account for each unit designating the name of the Unit Owner, the due date and amount of each Assessment, Special Assessment, if any, the amount paid upon the account, and the balance due.
  - (c) All audits, reviews, accounting statements, and financial reports of the Association or Condominiums.
  - (d) All contracts for work to be performed. Bids for work to be performed shall also be considered official records and shall be maintained for a period of 1 year.
- (12) Voting proxies, which shall be maintained for a period of 1 year from the date of the meeting for which the proxy was given.
- (13) All rental records where the Association is acting as agent for the rental of Units.

The official records of the Association shall be maintained in the county in which the Condominiums are located and be open to inspection by any Association member or the authorized representative of such member at all reasonable times. Failure to permit inspection of the Association records as provided herein entitles any person prevailing in an enforcement action to recover reasonable attorneys' fees from the person in control of the records who, directly or indirectly, knowingly denies access to the records for inspection. The right to inspect the records includes the right to make or obtain copies, at the reasonable expense, if any, of the Association member.

## 6. Officers.

Section 6.1 Executive Officers. The executive officers of the Association shall be a President, who shall be a Director, a Vice President, who shall be a Director, a Treasurer, a Secretary and an Assistant Secretary (none of whom need be Directors), all of whom shall be elected by the Board of Directors and who may be peremptorily removed at any meeting by concurrence of a majority of all of the Directors. A person may hold more than one office, except that the President may not also be the Secretary or Assistant Secretary. No person shall sign an instrument or perform an act in the capacity of more than one office. The Board of Directors from time to time shall elect such other officers and designate their powers and duties as the Board shall deem necessary or appropriate to manage the affairs of the Association.

Section 6.2 President. The President shall be the chief executive officer of the Association. He shall have all of the powers and duties that are usually vested in the office of president of an association.

OFF. REC. 16030P 0309

Exhibit "A" - Page 14

- Section 6.3 Vice President. The Vice President shall exercise the powers and perform the duties of the President in the absence or disability of the President. he also shall assist the President and exercise such other powers and perform such other duties as are incident to the office of an association and as shall otherwise be prescribed by the Directors.
- Section 6.4 Secretary. The Secretary shall keep the minutes of all the proceedings of the Directors and the members. He shall attend to the giving of all notices to the members and Directors and other notices required by law. He shall have custody of the seal of the Association and shall affix it to instruments requiring the seal when duly signed. He shall keep the records of the Association, except those of the Treasurer, and shall perform all other duties incident to the office of the secretary of an association and as may be required by the Directors or the President.
- Section 6.5 Assistant Secretary. The Assistant Secretary shall exercise the powers and perform the duties of the Secretary in the absence or disability of the Secretary.
- Section 6.6 Treasurer. The Treasurer shall have custody of all property of the Association, including funds, securities and evidences of indebtedness. He shall keep books of account for the Association in accordance with good accounting practices, which together with substantiating papers, shall be made available to the Board of Directors for examination at reasonable times. He shall submit a treasurer's report to the Board of Directors at reasonable intervals and shall perform all other duties incident to the office of treasurer. All monies and other valuable effects shall be kept for the benefit of the Association in such depositories as may be designated by a majority of the Board of Directors.
7. Compensation. Neither Directors nor officers shall receive compensation for their services as such, but this provision shall not preclude the Board of Directors from employing a Director or officer as an employee of the Association, nor preclude contracting with a Director or officer for the management of the Condominiums or for any other service to be supplied by such Director or officer. Directors and officers shall be compensated for all actual and proper out of pocket expenses relating to the proper discharge of their respective duties.
8. Resignations. Any Director or officer may resign his post at any time by written resignation, delivered to the President or Secretary, which shall take effect upon its receipt unless a later date is specified in the resignation, in which event the resignation shall be effective from such date unless withdrawn. The acceptance of a resignation shall not be required to make it effective.
9. Fiscal Management. The provisions for fiscal management of the Association set forth in the Declaration and Articles shall be supplemented by the following provisions:
- Section 9.1 Budget.
- (a) Adoption by Board; Items. The Board of Directors shall from time to time, and at least annually, prepare a budget for each of the Condominiums (which shall detail all accounts and items of expenses and contain at

OFF. REC. 16030P0310

Exhibit "A" - Page 15

least all items set forth in Section 718.504(20) of the Act, if applicable), determine the amount of Assessments payable by the Unit Owners and allocate and access expenses among the Unit Owners in accordance with the provisions hereof and of the Declarations. In addition to annual operating expenses, the budget shall include reserve accounts for capital expenditures and deferred maintenance. These accounts shall include, but not be limited to, roof replacement, building painting and pavement resurfacing. The amount of reserves shall be computed by means of a formula which is based upon estimated life and estimated replacement cost of each reserve item. Reserves shall not be required if the members of the Condominiums have, by a majority of the voting interests present at a duly called meeting of members, determined for a specific fiscal year to provide no reserves or reserves less adequate than required hereby. If a meeting of the Unit Owners has been called to provide no reserves or reserves less adequate than required, and such result is not attained or a quorum is not attained, the reserves as included in the budget, shall go into effect. The adoption of budgets for the Condominiums shall comply with the requirements hereinafter set forth:

- (i) Notice of Meeting. A copy of the proposed budget of Common Expenses shall be mailed to each Unit Owner not less than fourteen (14) days prior to the meeting of the Board of Directors at which the budget will be considered, together with a notice of that meeting indicating the time and place of such meetings. The meeting shall be open to Unit Owners, provided that such Unit Owners shall not have the right to participate and need not be recognized at such meeting.
- (ii) Special Membership Meeting. If a budget is adopted by the Board of Directors which requires Assessments against Unit Owners of a Condominium in any year exceeding one hundred fifteen (115%) percent of the voting interests to the Board of Directors, a special meeting of the Unit Owners of such Condominium shall be held within thirty (30) days or delivery of such application to the Board of Directors. Each Unit Owner shall be given at least ten (10) days' notice of said meeting. At the special meeting of the Condominium for which the required Assessments exceed one hundred fifteen (115%) percent of such Assessments for the preceding year, the Unit Owners of such Condominiums shall consider and adopt a budget.
- (iii) Determination of Budget Amount. In determining whether a budget requires Assessments against Unit Owners of a Condominium in any year exceeding one hundred fifteen (115%) percent of Assessments for the preceding year, there shall be excluded in the computations any

OFF. REC. 16030P0311

## Exhibit "A" - Page 16

authorized provisions for reasonable reserves made by the Board of Directors in respect of repair or replacement of the Condominium Property or in respect of anticipated expenses of the Association which are not anticipated to be incurred on a regular or annual basis, and there shall be excluded from such computation Assessments for improvements to the Condominium Property and expenses which are unique to specific Unit Owners.

- (b) Adoption by Membership. In the event that the Board of Directors shall be unable to adopt a budget in accordance with the requirements of Section 9.1(a) above, the Board of Directors may call a special meeting of Unit Owners for the purpose of considering and adopting such budget, which meeting shall be called and held in the manner provided for special meetings in Section 9.1(a), or propose a budget in writing to the members. If such budget is approved by a majority of the voting interests at the meeting or in writing, upon ratification by a majority of the Board of Directors, it shall become the budget for such year.
- (c) Failure of Quorum or to Adopt Substitute Budget. If a meeting of the Unit Owners has been called and a quorum is not attained or a substitute budget is not adopted by the Unit Owners, the budget adopted by the Board of Directors shall go into effect as scheduled.

## Section 9.2

Assessments. Assessments against the Unit Owners for their share of the items of the budget shall be made for the applicable calendar year annually in advance on or before December 20th preceding the year for which the Assessments are made. Such Assessments shall be due in equal installments, payable in advance on the first day of each month (or each quarter at the election of the Board) of the year for which the Assessments are made. If an annual Assessment is not made as required, an Assessment shall be presumed to have been made in the amount of the last prior assessment, and monthly (or quarterly) installments on such Assessment shall be due upon each installment payment date until changed by an amended Assessment. In the event the annual Assessment proves to be insufficient, the budget and assessment may be amended at any time by the Board of Directors. Unpaid Assessments for the remaining portion of the calendar year for which an amended Assessment is made shall be payable in as many equal installments as there are full months (or quarters) of the calendar year left as of the date of such amended Assessment, each such monthly (or quarterly) installment to be paid on the first day of the month (or quarter), commencing the first day of the next ensuing month (or quarter). If only a partial month (or quarter) remains, the amended Assessment shall be paid with the next regular installment in the following year, unless otherwise directed by the Board in its resolution.

## Section 9.3

Charges. Charges by the Association against members for other than Common Expenses shall be payable in advance. Charges for other than Common Expenses may be made only after approval of a member or when expressly provided for in the Declarations or the exhibits annexed thereto, as

OFF. REC. 16030P0312

## Exhibit "A" - Page 17

the same may be amended from time to time, which charges may include, without limitation, charges for the use of the Condominium Properties or recreation areas, maintenance services furnished at the expense of an Owner, other services furnished for the benefit of an Owner and surcharges, fines and damages and other sums due from such Owner.

- Section 9.4 Special Assessments for Emergencies. Special Assessments for Common Expenses for emergencies that cannot be paid from the annual Assessments for Common Expenses shall be due only after ten (10) days' notice is given to the Unit Owners concerned, and shall be paid in such manner as the Board of Directors of the Association may require in the notice of Special Assessment.
- Section 9.5 Depository. The depository of the Association shall be such bank or banks in the County as shall be designated from time to time by the Directors and in which the monies of the Association shall be deposited. Withdrawal of monies from these accounts shall be made only by checks signed by such person or persons as are authorized by the Directors. All sums collected by the Association from Assessments, Special Assessments, or contributions to working capital or otherwise may be commingled in a single fund or divided into more than one fund, as determined by a majority of the Board of Directors.
- Section 9.6 Acceleration of Assessment or Special Assessment Installments Upon Default. If a Unit Owner shall be in default in the payment of an installment upon an Assessment or Special Assessment, the Board of Directors may accelerate the remaining installments of the Assessment or Special Assessment upon notice to the Unit Owner and the then unpaid balance of the Assessment or Special Assessment shall be due upon the date stated in the notice, but not less than five (5) days after delivery of the notice to the Unit Owner, or not less than ten (10) days after the mailing of such notice to him by registered or certified mail, whichever shall first occur.
- Section 9.7 Fidelity Bonds. To the extent required by law, fidelity bonds in the principal sum of not less than \$10,000.00, for any officer or director shall be required by the Board of Directors for such officers who control or disburse Association's funds. The premiums on such bonds shall be paid by the Association as a Common Expense.
- Section 9.8 Accounting Records and Reports. Written summaries of the records described in Section 5(x)(11) of these By-Laws, in the form and manner specified below, shall be supplied to each Unit Owner annually.

Within sixty (60) days following the end of the fiscal year, the Board shall mail, or furnish by personal delivery, to each Unit Owner a complete financial report of actual receipts and expenditures for the previous twelve (12) months. The report shall show the amounts of receipts by accounts and receipt classifications and shall show the amounts of expenses by accounts and expense classifications, including, if applicable, but not limited to, the following:



OFF: 16030  
REC: 0313

## Exhibit "A" - Page 18

- (a) Cost for security;
- (b) Professional and management fees and expenses;
- (c) Taxes;
- (d) Costs for recreation facilities;
- (e) Expenses for refuse collection and utility services;
- (f) Expenses for lawn care;
- (g) Costs for building maintenance and repair;
- (h) Insurance costs;
- (i) Administrative and salary expenses; and
- (j) General reserves, maintenance reserves and depreciation reserves.

Section 9.9 Application of Payment. All Assessment and Special Assessment payments made by a Unit Owner shall be applied as provided herein and in the Declarations or as determined by the Board.

Section 9.10 Notice of Meetings. Notice of any meeting where Special Assessments against Unit Owners are to be considered for any reason shall specifically contain a statement that Special Assessments will be considered and the nature of any such Special Assessments.

10. Roster of Unit Owners. Each Unit Owner shall file with the Association a copy of the deed or other document showing his ownership. The Association shall maintain such information. The Association may rely upon the accuracy of such information for all purposes until notified in writing of changes therein as provided above. Only Unit owners of record on the date notice of any meeting requiring their vote is given shall be entitled to notice of and to vote at such meeting, unless prior to such meeting other Owners shall produce adequate evidence, as provided above, of their interest and shall waive in writing notice of such meeting.

11. Parliamentary Rules. Roberts' Rules of Order (latest edition) shall govern the conduct of the Association meetings when not in conflict with the Declarations, the Articles or these By-Laws.

12. Amendments. Except as in the Declarations provided otherwise, these By-Laws may be amended in the following manner:

Section 12.1 Notice. Notice of the subject matter of a proposed amendment shall be included in the notice of a meeting at which a proposed amendment is to be considered.

Section 12.2 Adoption. A resolution for the adoption of a proposed amendment may be proposed either by a majority of the Board of Directors or by not less than one-third (1/3) of the voting interests of the Association. Directors and members not present in person or by proxy at the meeting considering the amendment may express their approval in writing, provided that such approval is delivered to the Secretary at or prior to the meeting. The approval must be:

- (a) by not less than a majority of the voting

REC. 603000314

## Exhibit "A" - Page 19

interests of all members of the Association represented at a meeting at which a quorum has been attained and by not less than two-thirds (66 2/3%) percent of the entire Board of Directors; or

- (b) by not less than eighty (80%) percent of the voting interests of the members of the Association represented at a meeting at which a quorum has been attained; or
- (c) by not less than one hundred (100%) percent of the entire Board of Directors.

Section 12.3 Proviso. No amendment may be adopted which would eliminate, modify, prejudice, abridge or otherwise adversely affect any rights, benefits, privileges or priorities granted or reserved to the Developer or mortgagees in each instance. No amendment shall be made that is in conflict with the Articles or Declarations.

Section 12.4 Execution and Recording. A copy of each amendment shall be attached to a Certificate certifying that the amendment was duly adopted as an amendment of the Declarations and By-Laws, which certificate shall be executed by the President or Vice President and attested by the Secretary or Assistant Secretary of the Association with the formalities of a deed, or by the Developer alone if the amendment has been adopted consistent with the provisions of the Declarations allowing such action by the Developer. The amendment shall be effective when the certificate and a copy of the amendment is recorded in the Public Records of the County; provided, however, no amendment to these By-Laws shall be valid unless the first page of the amendment to be recorded shows the book and page of the public records where the Declarations are recorded.

Section 12.5 Procedure. The By-Laws shall not be revised or amended by reference to its title or number only. Proposals to amend the By-Laws shall contain the full text of the By-Laws to be amended; new words shall be inserted in the text underlined and words to be deleted shall be lined through with hyphens. However, if the proposed change is so extensive that this procedure would hinder rather than assist the understanding of the proposed amendment, underlining and hyphens as indicative of words added or deleted shall not be used, but instead a notation shall be inserted immediately preceding the proposed amendment in substantially the following language: "Substantial rewording of by law. See by law...for present text." Nonmaterial errors or omissions in the law process shall not invalidate an otherwise properly promulgated amendment.

13. Rules and Regulations. Annexed hereto as Schedule A and made a part hereof are rules and regulations concerning the use of portions of the Condominiums. The Board of Directors may, from time to time, modify, amend or add to such rules and regulations, except that subsequent to the date control of the Board is turned over by the Developer to Unit Owners other than the Developer, Owners of a majority of the voting interests of the Units represented at a meeting at which a quorum is present may overrule the Board with respect to any such modifications, amendments or additions. Copies of such modified, amended or additional rules and regulations shall be

OFF. 1603000315  
REC.

Exhibit "A" - Page 20

furnished by the Board of Directors to each affected Unit Owner not less than thirty (30) days prior to the effective date thereof. At no time may any rule or regulation be adopted which would prejudice the rights reserved to the Developer.

14. Construction. Wherever the context so permits, the singular shall include the plural, the plural shall include the singular, and the use of any gender shall be deemed to include all genders.
15. Captions. The captions herein are inserted only as a matter of convenience and for reference and in no way define or limit the scope of these By-Laws of the intent of any provision hereof.

RECORDED BY CLERICAL RECORDS DEPT.  
OF DADE COUNTY, FLORIDA  
RECORD VERIFIED  
HARVEY RUVIN  
CLERK, CLERICAL COURT

OFF. REC. 143C2PG 494

## BY-LAWS

OF

COSTA DEL SOL CONDOMINIUM T ASSOCIATION, INC.

A corporation not for profit organized  
under the laws of the State of Florida

1. Identity. These are the By-Laws of Costa del Sol Condominium T Association, Inc., (the "Association"), a corporation not for profit, incorporated under the laws of the State of Florida and organized for the purpose of administering that certain condominium located in Dade County, Florida, and known as Costa del Sol Condominium T (the "Condominium").
  - §1.1 Principal Office. The principal office of the Association shall be 700 N.W. 107th Avenue, Miami, Florida, 33172, or at such other place as may be subsequently designated by the Board of Directors.
  - §1.2 Fiscal Year. The fiscal year of the Association shall be the calendar year.
  - §1.3 Seal. The seal of the Association shall bear the name of the corporation, the word "Florida", the words "Corporation Not for Profit", and the year of incorporation.
  
2. Definitions. For convenience, the Florida Condominium Act shall be referred to as "Act" these By-Laws shall be referred to as the "By-Laws" and the Articles of Incorporation of the Association as the "Articles". The other terms used in these By-Laws shall have the same definition and meaning as those set forth in the Declaration for the Condominium, unless herein provided to the contrary, or unless the context otherwise requires.
  
3. Members.
  - §3.1 Annual Meeting. The annual members' meeting shall be held on the date, at the place and at the time determined by the Board of Directors from time to time, provided that there shall be an annual meeting every calendar year and, to the extent possible, no later than thirteen (13) months after the last preceding annual meeting. The purpose of the meeting shall be, except as provided herein to the contrary, to elect Directors and to transact any other business authorized to be transacted by the members, or as stated in the notice of the meeting sent to Unit Owners in advance thereof.
  - §3.2 Special Meetings. Special members' meetings shall be held at such places as provided herein for annual meetings, and may be called by the President or by a majority of the Board of Directors of the Association, and must be called by the President or Secretary upon receipt of a written request from a majority of all the voting interests of the membership of the Association. The business conducted at a special meeting shall be limited to that stated in the notice of the meeting. Additionally, special members' meetings may be called by ten (10%) percent of the voting interests of the Unit Owners of the Association to recall a member or members of the Board of Directors or as provided for in Section 9.01(a) (ii), hereof; which meetings shall be called and held in accordance with the terms and provisions of the Act and Section 4.3 hereof.
  - §3.3 Notice of Meeting; Waiver of Notice. Notice of a meeting of members stating the time and place and the purposes, for which the meeting is called shall be given by the President or Secretary. A copy of the notice shall be posted at a conspicuous place on the Condominium Property. The notice of the annual meeting